



BOARD OF MANAGEMENT SUNDAR INDUSTRIAL ESTATE (BOM-SIE)

Bidding Documents

For

“CONSTRUCTION OF STORE BACK SIDE OF RESCUE BUILDING AT SIE”

ITB # ED/SIE/CAPITAL/2024-25/CBRB

Volume I : Bidding Documents

Jan 2025

SUMMARY OF CONTENTS

<u>Sr. No.</u> <u>No</u>	<u>Subject</u>	<u>Page</u>
(I)	INVITATION FOR BIDS	03
(II)	INSTRUCTIONS TO BIDDERS & BIDDING DATA	07
(III)	BIDDING DATA	19
(IV)	FORM OF BID & SCHEDULES TO BID	21
(V)	CONDITIONS OF CONTRACT & CONTRACT DATA	35
(VI)	STANDARD FORMS	52
(VII)	TECHNICAL SPECIFICATIONS	61
(VIII)	DRAWINGS	63

INVITATION FOR BIDS

INVITATION FOR BIDS

1. BOM-SIE intends to hire a Contractor/Vendor/Supplier for CONSTRUCTION OF STORE BACK SIDE OF RESCUE BUILDING AT SUNDAR INDUSTRIAL ESTATE
2. Sealed Bids are invited for the above said work from Contractors registered with PEC (C6) or above Category, FBR, Sales Tax, Income Tax & PRA having experience of similar works.
3. Bidding will be conducted under the provision of PPRA Rules -2014 (amended up to date) on Single Stage One Envelope Basis
4. For bids submission on E-procurement, Bidders are requested to register at www.punjab.eprocure.gov.pk.
5. Bidding Documents are available on PPRA website: www.ppra.punjab.gov.pk, BOM-SIE website www.sie.com.pk and EPADS Portal i.e. <http://punjab.eprocure.gov.pk> free of cost.
6. **The Bidding documents, completed, signed, stamped must be submitted online E-Pak Acquisition and Disposal System (EPADS) Portal i.e. <http://punjab.eprocure.gov.pk> till 04-02-2025 by or before 11:00AM and bids shall be opened at same date on 11:50 AM, as per the PPRA Rules, 2014**
7. Bid must contain Bid Security in shape of Bank Guarantee / CDR / Bank Draft / Pay Order amounting to Rs. 155,326/- in favor of “PIEDMC Sundar Industrial Estate” (which is 2% of the estimated cost), without which the offer shall be rejected being non-responsive. The bid security must be attached in PDF format and posted in original in Bom-SIE office, before bid opening date.
8. Bids that are incomplete, not signed and stamped, late, or submitted by other than specified mode will not be considered.
9. In case, the firm is found Black-listed by any Department or provide false / misleading information, it's Bid will be cancelled and will be recommended for punitive action.

Note: BOM-SIE management may reject all bids or proposals at any time prior to the acceptance of bids or proposals, as provided under Rule-35 of Punjab Procurement Rules, 2014 (amended from time to time)

Yours faithfully,

The Engineer /HOD Engineering/BCD

INSTRUCTIONS TO BIDDERS

INSTRUCTIONS TO BIDDERS

TABLE OF CONTENTS

<i>Clause No.</i>	<i>Description</i>	<i>Page No.</i>
A. GENERAL		
IB.1	Scope of Bid & Source of Funds	10
IB.2	Eligible Bidders	10
IB.3	Cost of Bidding	10
B. BIDDING DOCUMENTS		
IB.4	Contents of Bidding Documents	10
IB.5	Clarification of Bidding Documents	11
IB.6	Amendment of Bidding Documents	11
C- PREPARATION OF BID		
IB.7	Language of Bid	12
IB.8	Documents Comprising the Bid	12
IB.9	Sufficiency of Bid	12
IB.10	Bid Prices, Currency of Bid & Payment	12
IB.11	Documents Establishing Bidder's Eligibility and Qualifications	13
IB.12	Documents Establishing Works Conformity to Bidding Documents	13
IB.13	Bidding Security	13
IB.14	Validity of Bids, Format, Signing and Submission of Bid	14
D-SUBMISSION OF BID		
IB.15	Deadline for Submission, Modification & Withdrawal of Bids	14
E. BID OPENING AND EVALUATION		
IB.16	Bid Opening, Clarification and Evaluation	15
IB.17	Process to be Confidential	17
F. AWARD OF CONTRACT		
IB.18	Qualification	17
IB.19	Award Criteria & Employers Right	17
IB.20	Notification of Award & Signing of Contract Agreement	18
IB.21	Performance Security	18
IB.22	Integrity Pact	18

INSTRUCTIONS TO BIDDERS

A. GENERAL

IB.1 Scope of Bid & Source of Funds

1.1 Scope of Bid

The Employer as defined in the Bidding Data (hereinafter called “the Employer”) wishes to receive Bids for the Works summarized in the Bidding Data (hereinafter referred to as “the Works”).

Bidders must quote for the complete scope of work. Any Bid covering partial scope of work will be rejected as non-responsive.

1.2 Source of Funds

The Employer has arranged funds from its own sources.

IB.2 Eligible Bidders

2.1 Bidding is open to all firms and persons meeting the following requirements:

- a) Registered with PEC C6 or above category, with Income Tax, Sales Tax & PRA, with active taxpayer, Documentary evidence to be attached.
- b) Bidder Shall submit minimum three (3) documentary evidence of similar works during last Five years.
- c) Bid Security 2% As stated in the advertisement

IB.3 Cost of Bidding

The bidder shall bear all costs associated with the preparation and submission of its bid and the Employer will in no case be responsible or liable for those costs, regardless of the conduct or outcome of the bidding process.

B. BIDDING DOCUMENTS

IB.4 Contents of Bidding Documents

4.1 In addition to Invitation for Bids, the Bidding Documents are those stated below, and should be read in conjunction with any Addendum issued in accordance with Sub- Clause IB.6.1.

1. Instructions to Bidders & Bidding Data
2. Form of Bid & Schedules to Bid

Schedules to Bid comprise the following:

- (i) Schedule A: Schedule of Prices
- (ii) Schedule B: Specific Works Data
- (iii) Schedule C: Works to be Performed by Subcontractors
- (iv) Schedule D: Proposed Program of Works

- (v) Schedule E: Method of Performing Works
 - (vi) Schedule F: Integrity Pact
3. Conditions of Contract & Contract Data
 4. Standard Forms:
 - (i) Form of Bid Security
 - (ii) Form of Performance Security
 - (iii) Form of Contract Agreement
 - (iv) Form of Bank Guarantee for Advance Payment
 5. Specifications
 6. Drawings, if any

IB.5 Clarification of Bidding Documents

- 5.1 A prospective bidder requiring any clarification(s) in respect of the Bidding Documents may notify through **EPADS**.

IB.6 Amendment of Bidding Documents

- 6.1 At any time prior to the deadline for submission of Bids, the Employer may, for any reason, whether at his own initiative or in response to a clarification requested by a prospective bidder, modify the Bidding Documents by issuing addendum.
- 6.2 Any addendum thus issued shall be part of the Bidding Documents pursuant to Sub- Clause 6.1 hereof, and shall be communicated in writing to all purchasers of the Bidding Documents. Prospective bidders shall acknowledge receipt of each addendum in writing to the Employer.
- 6.3 To afford prospective bidders reasonable time in which to take an addendum into account in preparing their Bids, the Employer may at its discretion extend the deadline for submission of Bids.

C. PREPARATION OF BIDS

IB.7 Language of Bid

- 7.1 The bid prepared by the bidder and all correspondence and documents relating to the Bid, exchanged by the bidder and the Employer shall be written in the English language, provided that any printed literature furnished by the bidder may be written in another language so long as accompanied by an English translation of its pertinent passages in which case, for purposes of interpretation of the Bid, the English translation shall govern.

IB.8 Documents Comprising the Bid

- 9.1 The bid prepared by the bidder shall comprise the following components:
 - (a) Covering Letter

- (b) Form of Bid duly filled, signed and sealed, in accordance with Sub-Clause IB.14.3.
- (c) Schedules (A to F) to Bid duly filled and initialed, in accordance with the instructions contained therein & in accordance with Sub-Clause IB14.3.
- (d) Bid Security furnished in accordance with Clause IB.13.
- (e) Power of Attorney in accordance with Sub-Clause IB 14.5.
- (f) Documentary evidence in accordance with Clause IB.11
- (g) Documentary evidence in accordance with Clause IB.12.

IB.9 Sufficiency of Bid

- 9.1 Each bidder shall satisfy himself before Bidding as to the correctness and sufficiency of his Bid and of the rates and prices entered in the Schedule of Prices, which rates and prices shall except in so far as it is otherwise expressly provided in the Contract, cover all his obligations under the Contract and all matters and things necessary for the proper completion of the Works.
- 9.2 The bidder is advised to obtain for himself at his own cost and responsibility all information that may be necessary for preparing the bid and entering into a Contract for execution of the Works.

IB.10 Bid Prices, Currency of Bid and Payment

- 10.1 The bidder shall fill up the Schedule of Prices (Schedule A to Bid) indicating the unit rates and prices of the Works to be performed under the Contract. Prices in the Schedule of Prices shall be entered keeping in view the instructions contained in the Preamble to Schedule of Prices.
- 10.2 Unless otherwise stipulated in the Conditions of Contract, prices quoted by the bidder shall remain fixed during the bidder's performance of the Contract and not subject to variation on any account.
- 10.3 The unit rates and prices in the Schedule of Prices shall be quoted by the bidder in the currency as stipulated in Bidding Data.

IB.11 Documents Establishing Bidder's Eligibility and Qualifications

- 11.1 Pursuant to Clause IB.8, the bidder shall furnish, as part of its bid, documents establishing the bidder's eligibility to bid and its qualifications to perform the Contract if its bid is accepted.
- 11.2 Bidder/Manufacturer must possess and provide evidence of its capability and the experience as stipulated in Bidding Data and the Qualification Criteria stipulated in the Bidding Documents.

IB.12 Documents Establishing Works' Conformity to Bidding Documents

- 12.1 The documentary evidence of the Works' conformity to the Bidding Documents may be in the form of literature, drawings and data and the bidder shall furnish documentation as set out in Bidding Data.
- 12.2 The bidder shall note that standards for workmanship, material and equipment, and references to brand names or catalogue numbers, if any, designated by the Employer in the Technical Provisions are intended to be descriptive only and not restrictive.

IB.13 Bid Security

- 13.1 Each bidder shall furnish, as part of his bid, at the option of the bidder, a Bid Security in the amount stipulated in Bidding Data in Pak. Rupees in the form of Deposit at Call or a Bank Guarantee issued by a Scheduled Bank in Pakistan in favour of the Employer valid for a period up to twenty eight (28) days beyond the bid validity date.
- 13.2 Any bid not accompanied by an acceptable Bid Security shall be rejected by the Employer as non-responsive.
- 13.3 The bid securities of unsuccessful bidders will be returned upon award of contract to the successful bidder or on the expiry of validity of Bid Security whichever is earlier.
- 13.4 The Bid Security of the successful bidder will be returned when the bidder has furnished the required Performance Security, pursuant to Clause IB.21 and signed the Contract Agreement, pursuant to Sub-Clauses IB.20.2 & 20.3.
- 13.5 The Bid Security may be forfeited:
- (a) if a bidder withdraws his bid during the period of bid validity; or
 - (b) if a bidder does not accept the correction of his Bid Price, pursuant to Sub- Clause 16.4 (b) hereof; or
 - (c) in the case of a successful bidder, if he fails to:
 - (i) furnish the required Performance Security in accordance with Clause IB.21, or
 - (ii) sign the Contract Agreement, in accordance with Sub-Clauses IB.20.2 & 20.3.

IB.14 Validity of Bids, Format, Signing and Submission of Bid

- 14.1 Bids shall remain valid for the period stipulated in the Bidding Data after the date of bid opening.
- 14.2 All Schedules to Bid are to be properly completed and signed.

- 14.3 No alteration is to be made in the Form of Bid except in filling up the blanks as directed. If any alteration be made or if these instructions be not fully complied with, the bid may be rejected.
- 14.4 Each bidder shall prepare Original and number of copies specified in the Bidding Data of the documents comprising the bid as described in Clause IB.8 and clearly mark them "ORIGINAL" and "COPY" as appropriate. In the Event of discrepancy between them, the original shall prevail.
- 14.5 The original and all copies of the bid shall be typed or written in indelible ink and shall be signed by a person or persons duly authorized to sign (in the case of copies, Photostats are also acceptable). This shall be indicated by submitting a written Power of Attorney authorizing the signatory of the bidder to act for and on behalf of the bidder. All pages of the bid shall be initialed and official seal be affixed by the person or persons signing the bid.
- 14.6 The Bid shall be delivered in person or sent by registered mail at the address to Employer as given in Bidding Data.

D. SUBMISSION OF BID

IB.15 Deadline for Submission, Modification & Withdrawal of Bids

- 15.1 Bids must be uploaded on EPADS not later than the time and date stipulated therein.
- 15.2 Bids submitted through telegraph, telex, fax or e-mail or in hard shall not be considered.
- 15.3 Withdrawal of a bid during the interval between the deadline for submission of bids and the expiration of the period of bid validity specified in the Form of Bid may result in forfeiture of the Bid Security pursuant to Sub-Clause IB.13.5(a).

E. BID OPENING AND EVALUATION

IB.16 Bid Opening, Clarification and Evaluation

- 16.1 The Employer will open the bids, through EPADS.
- 16.2 To assist in the examination, evaluation and comparison of Bids the Engineer/Employer may, at its discretion, ask the bidder for a clarification of its Bid. The request for clarification and the response shall be in writing and no change in the price or substance of the Bid shall be sought, offered or permitted.
- 16.3 (a) Prior to the detailed evaluation, pursuant to Sub-Clauses IB.16.7 to 16.9, the Engineer/Employer will determine the substantial responsiveness of each bid to the Bidding Documents. For purpose of these Clauses, a substantially responsive bid is one which conforms to all the terms and conditions of the Bidding Documents without material deviations. It will include to determine the requirements listed in Bidding Data

- (b) Arithmetical errors will be rectified on the following basis:

If there is a discrepancy between the unit price and total price that is obtained by multiplying the unit price and quantity, the unit price shall prevail and the

total price shall be corrected. If there is a discrepancy between the words and figures the amount in words shall prevail. If there is a discrepancy between the If the bidder does not accept the corrected amount of Bid, his Bid will be rejected and his Bid Security forfeited.

- 16.4 A Bid determined as substantially non-responsive will be rejected and will not subsequently be made responsive by the bidder by correction of the non-conformity.
- 16.5 Any minor informality or non-conformity or irregularity in a Bid which does not constitute a material deviation may be waived by Employer, provided such waiver does not prejudice or affect the relative ranking of any other bidders.
- 16.6 The Engineer/Employer will evaluate and compare only the bids previously determined to be substantially responsive pursuant to Sub-Clauses IB.16.4 to 16.6 as per requirements given hereunder. Bids will be evaluated for complete scope of works. The prices will be compared on the basis of the Evaluated Bid Price pursuant to Sub-Clause 16.8 herein below.

(a) Technical Evaluation

It will be examined in detail whether the Works offered by the bidder complies with the Technical Provisions of the Bidding Documents. For this purpose, the bidder's data submitted with the bid in Schedule B to Bid will be compared with technical features/criteria of the Works detailed in the Technical Provisions. Other technical information submitted with the bid regarding the Scope of Work will also be reviewed.

(b) Commercial Evaluation

It will be examined in detail whether the bids comply with the commercial/contractual conditions of the Bidding Documents. It is expected that no material deviation/stipulation shall be taken by the bidders.

16.8 Evaluated Bid Price

In evaluating the bids, the Engineer/Employer will determine for each bid in addition to the Bid Price, the following factors (adjustments) in the manner and to the extent indicated below to determine the Evaluated Bid Price:

- (i) making any correction for arithmetic errors pursuant to Sub-Clause 16.4 hereof.
- (ii) making an appropriate price adjustment for any other acceptable variation or deviation.
- (iii) making an appropriate price adjustment for Deviations in terms of Payments (if any and acceptable to the Employer).
- (iv) discount, if any, offered by the bidders as also read out and recorded at the time of bid opening.

16.9 Evaluation Methods

Pursuant to Sub-Clause 16.8, Para (ii), and (iii) following evaluation methods for price adjustments will be followed:

- (i) Price Adjustment for Technical Compliance
The cost of making good any deficiency resulting from technical noncompliance will be added to the Corrected Total Bid Price for comparison purposes only. The adjustments will be applied taking the highest price quoted by other bidders being evaluated in detail in their original Bids for corresponding item. In case of non-availability of price from other bidders, the price will be estimated by the Engineer/Employer.
- (ii) Price Adjustment for Commercial Compliance
The cost of making good any deficiency resulting from any quantifiable variations and deviations from the Bid Schedules and Conditions of Contract, as determined by the Engineer/Employer will be added to the Corrected Total Bid Price for comparison purpose only. Adjustment for commercial compliance will

- be added to the Corrected Total Bid Prices.
- (iii) Price Adjustment for Deviation in Terms of Payments
Refer to Bidding Data

IB.17 Process to be Confidential

- 17.1 Subject to Sub-Clause IB.16.3 heretofore, no bidder shall contact Engineer/Employer on any matter relating to its Bid from the time of the Bid opening to the time the bid evaluation result is announced by the Employer. The evaluation result shall be announced at least ten (10) days prior to award of Contract. The announcement to all bidders will include table(s) comprising read out prices, discounted prices, price adjustments made, final evaluated prices and recommendations against all the bids evaluated.
- 17.2 Any effort by a bidder to influence Engineer/Employer in the Bid evaluation, Bid comparison or Contract Award decisions may result in the rejection of his Bid. Whereas, any bidder feeling aggrieved may lodge a written complaint not later than fifteen (15) days after the announcement of the bid evaluation result, however, mere fact of lodging a complaint shall not warrant suspension of procurement process.

F. AWARD OF CONTRACT

IB.18. Post Qualification

- 18.1 The Employer, at any stage of the bid evaluation, having credible reasons for or *prima facie* evidence of any defect in supplier's or contractor's capacities, may require the suppliers or contractors to provide information concerning their professional, technical, financial, legal or managerial competence whether already pre-qualified or not:

Provided that such qualification shall only be laid down after recording reasons therefor in writing. They shall form part of the records of that bid evaluation report.

- 18.2 The determination will take into account the bidder's financial and technical capabilities. It will be based upon an examination of the documentary evidence of the bidders' qualifications submitted under Clause IB.11, as well as such other information required in the Bidding Documents.

IB.19 Award Criteria & Employer's Right

- 19.1 Subject to Sub-Clause IB.19.2, the Employer will award the Contract to the bidder whose bid has been determined to be substantially responsive to the Bidding Documents and who has offered the lowest evaluated Bid Price, provided that such bidder has been determined to be qualified to satisfactory perform the Contract in accordance with the provisions of Clause IB.18.
- 19.2 Not with standing Sub-Clause IB.19.1, the Employer reserves the right to accept or reject any bid, and to annul the bidding process and reject all bids, at

any time prior to award of Contract, without thereby incurring any liability to the affected bidders or any obligation to inform the affected bidders of the grounds for the Employer's action except that the grounds for its rejection of all bids shall upon request be communicated, to any bidder who submitted a bid, without justification of the grounds. Notice of the rejection of all the bids shall be given promptly to all the bidders.

IB.20 Notification of Award & Signing of Contract Agreement

- 20.1 Prior to expiration of the period of bid validity prescribed by the Employer, the Employer will notify the successful bidder in writing ("Letter of Acceptance") that his bid has been accepted.
- 20.2 Within seven (7) days from the date of furnishing of acceptable Performance Security under the Conditions of Contract, the Employer will send the successful bidder the Form of Contract Agreement provided in the Bidding Documents, incorporating all agreements between the parties.
- 20.3 The formal Agreement between the Employer and the successful bidder shall be executed within seven (7) days of the receipt of Form of Contract Agreement by the successful bidder from the Employer.

IB.21 Performance Security

- 21.1 The successful bidder shall furnish to the Employer a Performance Security in the form and the amount stipulated in the Conditions of Contract within a period of fourteen (14) days after the receipt of Letter of Acceptance.
- 21.2 Failure of the successful bidder to comply with the requirements of Sub-Clauses IB.20.2 & 20.3 or 21.1 or Clause IB.22 shall constitute sufficient grounds for the annulment of the award and forfeiture of the Bid Security.

IB.22 Integrity Pact

The Bidder shall sign and stamp the Form of Integrity Pact provided at Schedule-F to Bid in the Bidding Document for all Federal Government procurement contracts exceeding Rupees ten (10) million. Failure to provide such Integrity Pact shall make the bid non-responsive.

BIDDING DATA

1.1 Name of Employer

General Manager (Estate), BOM-SIE

Brief Description of Works

CONSTRUCTION OF STORE BACK SIDE OF RESCUE BUILDING AT SIE

5.1 (a) Employer's address:

Board of Management Sundar Industrial Estate
(BOMSIE)

Gate no 02 Board of Management, Sundar Industrial
Estates, Sundar-Raiwind Road, Lahore

(b) Engineer's address:

The Engineer /HOD Engineering/BCD BOM-SIE

10.3 Bid shall be quoted entirely in Pak. Rupees. The payment shall be made in Pak. Rupees.

12.1 (a) A detailed description of the Works, essential technical and performance characteristics.

(b) Complete set of technical information, description data, literature and drawings as required in accordance with Schedule B to Bid, Specific Works Data. This will include but not be limited to a sufficient number of drawings, photographs, catalogues, illustrations and such other information as is necessary to illustrate clearly the significant characteristics such as general construction dimensions and other relevant information about the works to be performed.

13.1 Amount of Bid Security

2% of Bid Amount

14.1 Period of Bid Validity

180 Days

14.4 Number of Copies of the Bid to be Submitted

Bids submitted through EPADS with PDF Format

14.6 Employer's Address for the Purpose of Bid Submission

Board of Management Sundar Industrial Estate (BOMSIE)

Gate no 02 Board of Management, Sundar Industrial Estate
Sundar-Raiwind Road, Lahore.

Tel: 042-35297291-3.

15.1 Deadline for Submission of Bids

As stated in advertisement

Opening of Bids

As stated in the advertisement

16.1 Venue of Bid Opening

Through EPADS

16.4 Responsiveness of Bids

Delete the Text and add following

A responsive bid will be one which fulfills the following criteria

- (i) the Bid is valid till required period,
- (ii) the Bid prices are firm during currency of contract (if it is a fixed price bid)
- (iii) completion period offered is within specified limits,
- (iv) the Bidder/Manufacturer is eligible to Bid and possesses the requisite experience, capability and qualification.
- (v) the Bid does not deviate from basic technical requirements and
- (vi) the Bids are generally In order, etc.

**FORM OF BID
AND SCHEDULES TO
BID**

FORM OF BID AND SCHEDULES TO BID
FORM OF BID

(LETTER OF OFFER)

Bid Reference No. _____

(Name of Works)

To:

Gentlemen,

1. Having examined the Bidding Documents including Instructions to Bidders, Bidding Data, Conditions of Contract, Contract Data, Specifications, Drawings, if any, Schedule of Prices and Addenda Nos.
_____ for the execution of the above-named Works, we, the undersigned, being a company doing business under the name of and address _____ and _____ and being duly incorporated under the laws of Pakistan hereby offer to execute and complete such Works and remedy any defects therein in conformity with the said Documents including Addenda thereto for the Total Bid Price of Rs _____ (Rupees _____) or such other sum as may be ascertained in accordance with the said Documents.
2. We understand that all the Schedules attached hereto form part of this Bid.
3. As security for due performance of the undertakings and obligations of this Bid, we submit herewith a Bid Security in the amount of _____ drawn in your favour or made payable to you and valid for a period of twenty eight (28) days beyond the period of validity of Bid.
4. We undertake, if our Bid is accepted, to commence the Works and to deliver and complete the Works comprised in the Contract within the time(s) stated in Contract Data.
5. We agree to abide by this Bid for the period of _____ days from the date fixed for receiving the same and it shall remain binding upon us and may be accepted at any time before the expiration of that period.

6. Unless and until a formal Agreement is prepared and executed, this Bid, together with your written acceptance thereof, shall constitute a binding contract between us.
7. We undertake, if our Bid is accepted, to execute the Performance Security referred to in Conditions of Contract for the due performance of the Contract.
8. We understand that you are not bound to accept the lowest or any bid you may receive.
9. We do hereby declare that the Bid is made without any collusion, comparison of figures or arrangement with any other person or persons making a bid for the Works.

Dated this _____ day _____, 20
of _____

Signature _____

in the capacity of _____ duly authorized to sign bid for and on
behalf of _____

(Name of Bidder in Block
Capitals)

(Seal)

Address

Witness:

(Signature) _____

Name: _____

Address: _____

SCHEDULES TO BID INCLUDE THE FOLLOWING:

- ▣ Schedule A to Bid: Schedule of Prices (BOQ)
- ▣ Schedule B to Bid: Specific Works Data
- ▣ Schedule C to Bid: Works to be Performed by Subcontractors
- ▣ Schedule D to Bid: Proposed Programme of Works
- ▣ Schedule E to Bid: Method of Performing Works
- ▣ Schedule F to Bid: Integrity Pact]

SCHEDULE – A TO BID

SCHEDULE OF PRICES

<u>Sr. No.</u>		<u>Page No.</u>
1.	Preamble to Schedule of Prices	
2.	Schedule of Prices	

PREAMBLE TO SCHEDULE OF PRICES

1. General

- 1.1 The Schedule of Prices shall be read in conjunction with the Conditions of Contract, Contract Data together with the Specifications and Drawings, if any.
- 1.2 The Contract shall be for the whole of the Works as described in these Bidding Documents. Bids must be for the complete scope of works.

2. Description

- 2.1 The general directions and descriptions of works and materials are not necessarily repeated nor summarized in the Schedule of Prices. References to the relevant sections of the Bidding Documents shall be made before entering prices against each item in the Schedule of Prices.

3. Units & Abbreviations

- 3.1 Units of measurement, symbols and abbreviations expressed in the Bidding Documents shall comply with as given in the BOQ (Note: The abbreviations to be used in the Schedule of Prices to be defined by the Employer).

4. Rates and Prices

- 4.1 Except as otherwise expressly provided under the Conditions of Contract, the rates and amounts entered in the Schedule of Prices shall be the rates at which the Contractor shall be paid and shall be the full inclusive value of the works set forth or implied in the Contract; except for the amounts reimbursable, if any to the Contractor under the Contract.
- 4.2 Unless otherwise stipulated in the Contract Data, the rates and prices entered by the bidder shall not be subject to adjustment during the performance of the Contract.
- 4.3 All duties, taxes by Federal and Provincial Govt, PRA Tax and other levies payable by the Contractor shall be included in the rates and prices.
- 4.4 The whole cost of complying with the provisions of the Contract shall be included in the items provided in the Schedule of Prices, and where no items are provided, the cost shall be deemed to be distributed among the rates and prices entered for the related items of the Works and no separate payment will be made for those items.

The rates, prices and amounts shall be entered against each item in the Schedule of Prices. Any item against which no rate or price is entered by the bidder will not be paid for by the Employer when executed and shall be deemed covered by the rates and prices for other items in the Schedule of Prices.

4.5 (a) The bidder shall be deemed to have obtained all information as to and all requirements related thereto which may affect the bid price.

(b) The Contractor shall be responsible to make complete arrangements for the transportation of the Plant

4.6 The Contractor shall provide for all parts of the Works to be completed in every respect. Notwithstanding that any details, accessories, etc. required for the complete installation and satisfactory operation of the Works, are not specifically mentioned in the Specifications, such details shall be considered as included in the Contract Price.

5. Bid Prices

5.1 Break-up of Bid Prices

The various elements of Bid Prices shall be quoted as detailed by the Employer in the format of Schedule of Prices.

The bidder shall recognize such elements of the costs which he expects to incur the performance of the Works and shall include all such costs in the rates and amounts entered in the Schedule of Prices.

5.2 Total Bid Price

The total of bid prices in the Schedule of Prices shall be entered in the Summary of Bid Prices.

6. Provisional Sums

6.1 Provisional Sums included and so designated in the Schedule of Prices if any, shall be expended in whole or in part at the direction and discretion of the Engineer/Employer. The Contractor will only receive payment in respect of Provisional Sums if he has been instructed by the Engineer/Employer to utilise such sums.

SCHEDULE OF PRICES

**BOARD OF MANAGEMENT SUNDAR INDUSTRIAL ESTATES RAIWAND
ROAD LAHORE (BOM_SIE) CONSTRUCTION OF STORE BACK SIDE OF
RESCUE BUILDING AT SIE"**

A) GREY STRUCTURE WORKS						
Sr #	Description	MRS 2024 2nd Bi- Annual CH/ item	Unit	Qty	Rate	Amount
1	Excavation					
	Excavation in foundation of building, bridges, and other structures, including dagbelling, dressing, refilling around structure with excavated earth, watering and ramming lead upto one chain (30 m) and lift upto 5 ft. (1.5 m) in ordinary soil. Complete in all respects as per drawings and as directed by the engineer incharge.					
	1) a) By Excavator (ii) Ordinary soil	3/21/2/a /ii	Cft	6,444.50000	10.79400	69,561.93300
2	Plain Cement Concrete (Ratio 1:2:4)					
	Cement concrete plain including placing, compacting, finishing and curing (including screening and washing of stone aggregate) (Ratio 1:2:4). Complete in all respects as per drawings and as directed by the engineer incharge.					
	Under Floors	6/5 (f)	Cft	145.75000	505.89000	73,733.46750
3	Plain Cement Concrete (Ratio 1:4:8) in Outside Area					
	Cement concrete plain including placing, compacting, finishing and curing (including screening and washing of stone aggregate) (Ratio 1:4:8). Complete in all respects as per drawings and as directed by the engineer incharge.					
i	Under Manholes	6/5 (i)	Cft	106.89300	383.39400	40,982.13484
4	Termite Proofing in Inside Area					
	praying termite proofing by using liquid FMC/ Biflex/ Terminex Exin/ Ms Hextar or equivalent @ specified suspension concentrate(SC), Mixing Ability-HEXTAR with Ratio (1:250) = 540 Sft or equivalent approved liquid applying with shower and certificate will be provided by the contractor for 10-years complete in all respect .asapproved by the Engineer Incharge	26/45	Sft	583.00000	12.55000	7,316.65000
5	Good Soil (Ghussi) Filling Under Floor Main Hall					

	Providing and laying good quality / local sand cushion from approved source (compacted in layers not exceeding 6" thickness) by mechanized means including the cost of front end loader, vibratory roller and all lead and lifts, dressing, watering complete in all respect as approved and directed by the Engineer Incharge	18/24	Cft	6,444.500	52.10000	335,758.45000
6	DPC (3" Thick)					
	Providing and laying damp proof course of cement concrete 1:2: 4(using cement, sand and shingle), including bitumen coating :- (b/i) with one coat bitumen and one coat polythene sheet 500gauge					
	i) 1½" thick (40 mm)	6/36/ (b)i	Cft	197.07563	124.79950	24,594.94009
7	Brick Ballast (2" Thick)					
	Providing, laying, watering and ramming brick ballast 1½" to 2"(40 mm to 50 mm) gauge mixed with 25% sand, for floor foundation. Complete in all respects as per drawings and as directed by the engineer incharge.	10/4	Cft	145.75000	135.82500	19,796.49375
8	Brick Masonry Work in Foundation					
i	Pacca brick work in foundation and plinth in cement sand mortar ratio 1:4. Complete in all respects as per drawings and as directed by the engineer incharge.					
	Total Brick Masonry Work	7/4 (i)	Cft	856.670869	419.98400	359,788.05825
9	Brick Masonry Work in super structure					
	Pacca brick work in super structure cement sand mortar ratio 1:4. Complete in all respects as per drawings and as directed by the engineer incharge.					
	Ground Floor Total Brick Masonry Work (1:4)	7/5(i)	Cft	1,483.68800	446.93400	663,110.61259
10	R.C.C Work (3000 Psi)					
	Providing and laying reinforced cement concrete (3000 Psi) (including prestressed concrete), using coarse sand and screened graded and washed aggregate, in required shape and design, including forms, moulds, shuttering, lifting, compacting, curing, rendering and finishing exposed surface (but excluding the cost of steel reinforcement, its fabrication and placing in position, etc.). Complete in all respects as per drawings and as directed by the engineer incharge.					
i	Slab 1:1 1/2:3	6/6 (a)(i)(2)	Cft	944.19422	848.55000	801,196.00538
ii	Columns, stair & beams p/wall 1:1 1/2:3	6/6 (a)(i)(2)	Cft	498.87500	848.55000	423,320.38125
11	Reinforcement					

	Fabrication of mild steel reinforcement for cement concrete, including cutting, bending, laying in position, making joints and fastenings, including cost of binding wire and labour charges for binding of steel reinforcement (also includes removal of rust from bars), Deformed bars (Grade-60). Complete in all respects as per drawings and as directed by the engineer incharge.	6/12/b/ii	Kg	2,443.0630	358.70650	876,342.57801
12	Plastering					
i	Cement plaster (1:4) upto 20' (6.00 m) height, 1/2" (13 mm) thick. Complete in all respects as per drawings and as directed by the engineer incharge.	11/9 b.	Sft	3,956.5000	47.16950	186,626.12675
13	RCC Plastering					
iii	Cement plaster 3/8" (10 mm) thick under soffit of R.C.C. roof slabs only, upto 20' height (1:4). Complete in all respects as per drawings and as directed by the engineer incharge.	11/10 /c	Sft	1,784.63150	52.41850	93,547.70628
14	Top Roof Treatment					
	Providing and laying roof insulation (thermopore sheet 1" (25 mm) thick), comprising of single layer of tiles 9"x4½"x1½" (225x113x40 mm) grouted with cement sand mortar 1:3 laid over 2" (50 mm) thick earth (including mud plaster) over thermopore sheet, over polythene sheet 300 gauge, over a layer of bitumen. Complete in all respects as per drawings and as directed by the engineer incharge.					
	ii) Thermopore sheet 1" (25 mm) thick	9/35 (iii)	Sft	944.1930	196.69400	185,717.09794
15	Khuras on Roof					
	Khuras on roof 2'x2'x6" (600x600x150mm). Complete in all respects as per drawings and as directed by the engineer incharge.	9/15	No	2.00	1,217.050	2,434.10000
A	TOTAL COST OF GREY STRUCTURE WORKS As Per MRS				Rs	4,163,826.7356
B	Finish Works(MRS)					
1	Surface Rendering					-
	Wall					
	Preparing surface and painting with emulsion paint (03 coats). Complete in all respects as per drawings and as directed by the engineer incharge.					
i	a) first coat	13/31	Sft	5,844.886	17.0765	99,810.196
ii	b) 2nd and 3rd (each subsequent coat)	13/31	Sft	5,844.886	13.2185	77,260.626
2	Glass Works					

	Providing and fitting all types of glazed aluminium windows of anodised bronze colour partly fixed and partly sliding using delux sections of approved manufacturer having frame size of 100 x 20 mm (4"x3/4") and leaf frame sections of 50 x 20 mm (2"x3/4"), all of 1.6mm thickness including 5 mm thick imported tinted glass with rubber gasket using approved standard latches, hardware etc. Complete in all respects as per drawings and as directed by the engineer incharge.	25/52	Sft	462.000	1,312.450	606,351.900
3	Carpentry Works					
	Providing and fixing 2" wide MS/ GI Chowkat singel/double rebate made of 16 SWG MS sheet pressed/welded / supported with M.S. flat 1-1/4"x1/8" i/c 6"long M.S. Flat 1"x1/8"hold fasts (6-Nos) welded/ screwed, punching of lock holecovered with MSBox,coating with antirust paint including filling with cement sand mortar (1:8) and embedding hold fast in cement concrete (1:2:4) ,complete in all respect as approved and directed by Engineer Incharge					
	ii) 10.5 " wide	12/17/ii	Sft	63.8750	792.3000	50,608.1625
	Flooring					
18	Floor Tile					
	Providing and laying superb quality Ceramic tile floors of Master brand of specifiedsize, Glossy / Matt / Texture of approved Color and Shade as per approved design with adhesive bond, over 3/4" thick (1:2) cement sand plaster i/c the cost of sealer for finishing the joints i/c cutting grinding complete in all respect sand as approved and directed by the Engineer Incharge.					
i	12"x18"/12"x24"/10"x24" /8"x24"/12"x36"	10/24/i	Sft	1,120.280	319.600	358,041.488
4	Skirting 4" High					
	Tile skirting laid in 1:2 cement mortar, over 3/4"(20 mm) thick cement mortar, 1:2 including cement washing and filling joints complete:-					
i	(b) mosaic tiles	10/35/b	Sft	123.423	369.8395	45,646.701
5	False Ceiling Works					-
i	Providing and fixing false ceiling comprises of Gypsum board laminated sheet of size 2'x2'/2'x3'/3'x3' of specified design and thickness i/c cost of fixture si.egalvanized angle1"x1"at wal lsides, galvanized tee 1 1/4"x1" and 1 1/2"x1" bothat4' c/c (made of Taiwan CKM or equivalent), hanging with G.I/Copper wire 16 SWG, G.I hook, Rawal Plugetc :complete in all respects as approved and directed by the Engineer Incharge.					
	iv) 12 mm thick	9/48/iv	Sft	1,166.000	159.850	186,385.100
6	Fair face Gutka					

	Providing and laying fair face Gutka cladding laid in (1:2) cement / red posso mortar having 1/4" thick groove finish i/c cost of 8 SWG wire in shape of 8 placed horizontally and vertically at 36" and 18" c/c respectively i/c cutting charges as per approved drawing , complete in all respect as approved and directed by the Engineer Incharge					
	ii. 2-1/4" x 3" x 9	7/27/ii	Sft	1,978.250	227.000	449,062.750
B	TOTAL COST OF FINISHES WORKS MRS				Rs	1,873,166.922
C	Finish Works(NMRS)					
1	Carpentary Works					
	Providing and fixing 1½" (40 mm) thick wooden door frame of 1½"x 3" wide vrtical & 1½"x 3" Horizontal bracing @ 9"c/c of kail, yellow pine or deodar wood panelled doors comprising of 2.5mm thick commercial or malaysia3ply under proper pressure etc including the cast of nails, tower bolt, handles, glue,lacure & door locks preparing surface and Lacquer polish to reveal wooden grains by application of multiple coats of wood sealer, sand papering with different no. of sand paper sand lacquer to make glossy surface i/c the cost of cotton, thinner, wood sealer complete in all respect. (Included all taxes & T&P)	NMRS	Sft	119.000	800.000	95,200.00000
C	TOTAL COST OF FINISHES WORKS NMRS				Rs	95,200.00000
D	DISTRIBUTION BOARD					
1	P/F wall mounted DB (Distribution Board) made with 16SWG Sheet (Recessded/Surface mounted Type), Powder coated Paint, i/c the cost of Lock, Indication lights,Thimble, Copper Comb, Wiring, Netural & Earth Bar, Door Earthing, Digital Voltmeter,Digital Ammeter,Volt Selector Switch,Ammeter selector switch,Current Transformers and Controles Complete in all respect as approved and directed by the Engineer Incharge (Breakers will be Paid Separately). 6" deep, 75~100A (30"x22"x6"). Provision of space for future MCBs RC: 10 kA.	24/93/a/ii	No	1.000	18,997.800	18,997.8000
i	Incoming					
	60 Amps 4 pole Moulded Case Circuit Breaker (MCCB) RC:10 KA	24/89/d/iii	No	1.000	12,448.250	12,448.250
ii	Outgoing					-
iii	10 Amps Single Pole MCBs RC: 10 kA for light circuit.	24/89/a/ii	No	9.000	1,128.850	10,159.650
iv	20 Amps Single Pole MCBs RC: 10 kA for power sockets and Split Ac.	24/89/a/ii	No	1.000	1,128.850	1,128.850
	CIRCUIT POINT WIRING					
2	Switch Socket & Outlets					

	P/F PVC double layer Switch kit Faceplate with specified switch holes i/c the cost of switches / sockets / dimmer made of Hi-Life / Bush / Schenider, screws complete as approved and directed by the Engineer Incharge					
3	Circuit point wiring					
	One way					
	Small					
iii	03 Gange	24/108(a) (iii)	No	3.000	878.100	2,634.300
iv	Three pin Light Plug 10/13 Amp	24/108(a) (iv)	No	10.000	744.550	7,445.500
v	Telephone / TV/Datacable socket	24/108(a) (v)	No	2.000	652.550	1,305.100
vi	Fan Dimmer	24/108(a) (vi)	No	2.000	730.700	1,461.400
	Larg					
x	06 Gange	24/108(b) (iii)	No	10.000	1,395.950	13,959.500
D	Total Dist. Board As per MRS			Amount Rs		69,540.350
E	FITTINGS, FIXTURES & FANS- MRs					
1	Providing and fixing Copper winded Exhaust fan with louver and shutter made of Pak/Younas/G.F.C. i/c the cost of necessary cable and hardware for connection from ceiling rose complete as approved and directed by Engineer Incharge. Plastic body					
ii	12 " dia	24/105/ a/ ii	No	2.000	5,508.100	11,016.200
2	Ceilling Fans					-
	Providing and fixing Copper winded ceiling fan made of Pak/Younas/G.F.C or NEECA approved equivalent i/c the cost of necessary cable and hardware for connection as approved and directed by Engineer Incharge					-
	iii) 56"	24/107/ iii	No	12.000	9,259.400	111,112.800
E	Total Electrical Schedule Items(Fitting Fixture & Fans)As perMRS			Amount Rs		122,129.000
	CIRCUIT POINT WIRING(MRS)					
F	Cables					
1	Supply & erection of single core in prelaid PVC insulated copper conductor cable in prelaid PVC pipe/M.S conduit/G.I. pipe/wooden strip batten casing an capping / G.I. wire /trenches (rate for cables only).					
	ii) 7/0.74mm (7/0.029") (As CPC)	24/10/a/ iii	RFt	1,352.716	56.500	76,428.454
	i) 3/0.74mm (3/0.029") (As P+N)	24/10/a/ i	RFT	1,304.002	35.900	46,813.672
v	4 Core Cable PVC					

	Supply and erection of PVC insulated, PVC sheathed copper conductor cable,600/1000 volt non amoroud grade cable in, prelaid G.I pipe /M.S. conduit/PVC pipe/G.I wire/trenches, etc:-					
vi	i) 2.5 mm(7/0.029")	24/13/c/ iii	Rft	400.000	177.800	71,120.000
2	Circuit Protective Conductor (CPC)					
	PVC Conduit & Accessories					
	Supply and erection of PVC pipe for wiring recessed in walls, including inspection boxes, pull boxes, hooks, cutting jharries, and repairing surface, etc., complete with all specials					
i	i) 20 mm (3/4") dia. PVC conduit for Point wiring.	24/3ii	Rft	281.3495	114.350	32,172.315
ii	ii) 25mm (1") dia. PVC conduit for 15amp socket and split A/C's	24/3/iii	Rft	100.000	135.950	13,595.000
iii	i) 50 mm(2") dia. PVC conduit.	24/3 /vi	Rft	50.000	234.300	11,715.000
F	Total Electrical Schedule ItemsAs perMRS			Amount Rs		251,844.441
G	Electrical NON-MRS					
1	FITTINGS, FIXTURES & FANS- NON-MRs					
i	Providing ,installation ,testing and commissioning of the following lighting fixture including all accessories like electronic ballast, drivery circuitry , lamps, mountings etc. Complete in all respects , make as approved by consultant .					
	Down light with 1x12 Watt Led Lamp Type LED COMFO V2 Mak OSRAM or approved euivalent. P.F=0.9.	NMRS	Each	12.000	1,630.000	19,560.000
ii	Down light with 1x12 Watt Led Lamp Type LED COMFO V2 Mak OSRAM or approved euivalent. P.F=0.9.	NMRS	Each	50.000	900.000	45,000.000
G	Total Electrical ItemsAs perNON-MRS			Amount Rs		64,560.000
H	PUBLIC HEALTH WORKS (Schedule)					
1	Providing, fixing, testing and commissioning of μ-PVC (Unplasticized Polyvinyl Chloride) Nikasi / waste pipe make of Dadex/ Popular/ Beta or equivalent, plain/ socket ended conforming to codeEN-1329 of specified SDR (Standard Dimension Ratio) including the cost of specials and Solvents complete in all respect as approved and directed by the Engineer Incharge.					
	b-Type (SDR 32.5/SN-8)					
	(v)4"(110 mm)	19/47/v	Rft	200.00	274.200	54,840.000

H	Total Public Health Schedule Items As Per-MRS				Rs	54,840.000
I	Total Schedule Items (A+B+D+E+F+H)					6,535,347.449
J	J) INCREASE EFFECT					
	J) Schedule Items Rs. 6,535,347.449 X _____ % Above /Below				Rs.	
K	K) Total (I+J)				Rs.	
L	L) Total Non MRS (C+G)					
M	M) Total (K+L)					
N	N) 16% PRA on (M)				Rs.	
O	O) Grand Total (M+N)				Rs.	

Signature & Stamp of BOM-SIE_____ Signature & Stamp of Contractor_____

SCHEDULE - B TO BID

***SPECIFIC WORKS DATA**

WORKS TO BE PERFORMED BY SUBCONTRACTORS

The bidder will do the work with his own forces except the work listed below which he intends to sub-contract.

Items of Works to be Sub-Contracted	Name and address of Sub-Contractors	Statement of works previously executed (attach evidence)
-------------------------------------	-------------------------------------	--

Note:

1. No change of Sub-Contractors shall be made by the bidder without prior approval of the Employer.
2. The truthfulness and accuracy of the statement as to the experience of Sub-Contractors is guaranteed by the bidder. The Employer’s judgment shall be final as to the evaluation of the experience of Sub-Contractors submitted by the bidder.
3. Statement of similar works shall include description, location & value of works, year completed and name & address of the clients.

SCHEDULE – D TO BID

PROPOSED PROGRAMME OF WORKS

Bidder shall provide a programme in a bar-chart showing the sequence of work items by which he proposes to complete the Works of the entire Contract. The programme should indicate the sequence of work items and the period of time during which he proposes to complete the Works including the activities like designing, schedule of submittal of drawings, ordering and procurement of materials, manufacturing, delivering, construction of civil works, erection, testing and commissioning of Works to be supplied under the Contract.

SCHEDULE – E TO BID

METHOD OF PERFORMING WORKS

The bidder is required to submit a narrative outlining the method of performing the Works. The narrative should indicate in detail and include but not be limited to:

- ▣ The sequence and methods in which he proposes to carry out the Works, including the number of shifts per day and hours per shift, he expects to work.
- ▣ A list of all major items of constructional and erectional plant, tools and vehicles proposed to be used in delivering/carrying out the Works at Site
- ▣ The procedure for installation of equipment and transportation of equipment and materials to the site.
- ▣ Organization chart indicating head office & field office personnel involved in management, supervision and engineering of the Works to be done under the Contract.

(INTEGRITY PACT)

**DECLARATION OF FEES, COMMISSION AND BROKERAGE ETC.
PAYABLE BY THE SUPPLIERS OF GOODS, SERVICES & WORKS IN
CONTRACTS WORTH RS. 10.00 MILLION OR MORE**

Contract No. _____ Dated _____
Contract Value: _____
Contract Title: _____

..... [name of Supplier] hereby declares that it has not obtained or induced the procurement of any contract, right, interest, privilege or other obligation or benefit from Government of Pakistan (GoP) or any administrative subdivision or agency thereof or any other entity owned or controlled by GoP through any corrupt business practice.

Without limiting the generality of the foregoing, [name of Supplier] represents and warrants that it has fully declared the brokerage, commission, fees etc. paid or payable to anyone and not given or agreed to give and shall not give or agree to give to anyone within or outside Pakistan either directly or indirectly through any natural or juridical person, including its affiliate, agent, associate, broker, consultant, director, promoter, shareholder, sponsor or subsidiary, any commission, gratification, bribe, finder's fee or kickback, whether described as consultation fee or otherwise, with the object of obtaining or inducing the procurement of a contract, right, interest, privilege or other obligation or benefit in whatsoever form from GoP, except that which has been expressly declared pursuant hereto.

[name of Supplier] certifies that it has made and will make full disclosure of all agreements and arrangements with all persons in respect of or related to the transaction with GoP and has not taken any action or will not take any action to circumvent the above declaration, representation or warranty.

[name of Supplier] accepts full responsibility and strict liability for making any false declaration, not making full disclosure, misrepresenting facts or taking any action likely to defeat the purpose of this declaration, representation and warranty. It agrees that any contract, right, interest, privilege or other obligation or benefit obtained or procured as aforesaid shall, without prejudice to any other rights and remedies available to GoP under any law, contract or other instrument, be voidable at the option of GoP.

Notwithstanding any rights and remedies exercised by GoP in this regard, [name of Supplier] agrees to indemnify GoP for any loss or damage incurred by it on account of its corrupt business practices and further pay compensation to GoP in an amount equivalent to ten times the sum of any commission, gratification, bribe, finder's fee or kickback given by [name of Supplier] as aforesaid for the purpose of obtaining or inducing the procurement of any contract, right, interest, privilege or other obligation or benefit in whatsoever form from GoP.

Name of Buyer:
..... Signature:

Name of Seller/Supplier:
Signature:

[Seal]

[Seal]

CONDITIONS OF CONTRACT & CONTRACT DATA

CONDITIONS OF CONTRACT

TABLE OF CONTENTS

CONDITIONS OF CONTRACT

<i>Clause No.</i>	<i>Description</i>	<i>Page No.</i>
1.	General Provisions	37
2.	The Employer	39
3.	Engineer's/Employer's Representatives	39
4.	The Contractor	40
5.	Design by Contractor	40
6.	Employer's Risks	41
7.	Time for Completion	42
8.	Taking Over	42
9.	Remedying Defects	42
10.	Variations And Claims	43
11.	Contract Price And Payment	44
12.	Default	45
13.	Risks And Responsibilities	46
14.	Insurance	47
15.	Resolution of Disputes	48
16.	Integrity Pact	48

CONDITIONS OF CONTRACT

1. GENERAL PROVISIONS

1.1 Definitions

In the Contract as defined below, the words and expressions defined shall have the following meanings assigned to them, except where the context requires otherwise:

The Contract

- 1.1.1 “Contract” means the Contract Agreement and the other documents listed in the Contract Data.
- 1.1.2 “Specifications” means the document as listed in the Contract Data, including Employer’s requirements in respect of design to be carried out by the Contractor (if any), and any Variation to such document.
- 1.1.3 “Drawings” means the Employer’s drawings of the Works as listed in the Contract Data, and any Variation to such drawings.

Persons

- 1.1.4 “Employer” means the person named in the Contract Data and the legal successors in title to this person, but not (except with the consent of the Contractor) any assignee.
- 1.1.5 “Contractor” means the person named in the Contract Data and the legal successors in title to this person, but not (except with the consent of the Employer) any assignee.
- 1.1.6 “Party” means either the Employer or the Contractor.

Dates, Times and Periods

- 1.1.7 “Commencement Date” means the date fourteen (14) days after the date the Contract comes into effect or any other date named in the Contract Data.
- 1.1.8 “Day” means a calendar day
- 1.1.9 “Time for Completion” means the time for completing the Works as stated in the Contract Data (or as extended under Sub-Clause 7.3), calculated from the Commencement Date.

Money and Payments

- 1.1.10 “Cost” means all expenditure properly incurred (or to be incurred) by the Contractor, whether on or off the Site, including overheads and similar charges but does not include any allowance for profit.

Other Definitions

- 1.1.11 “Contractor’s Equipment” means all machinery, apparatus and other things required for the execution of the Works but does not include Materials or Plant intended to form part of the Works.
- 1.1.12 “Country” means the Islamic Republic of Pakistan.
- 1.1.13 “Employer’s Risks” means those matters listed in Sub-Clause 6.1.
- 1.1.14 “Force Majeure” means an event or circumstance which makes performance of a Party’s obligations illegal or impracticable and which is beyond that Party’s reasonable control.
- 1.1.15 “Materials” means things of all kinds (other than Plant) to be supplied and incorporated in the Works by the Contractor.
- 1.1.16 “Plant” means the machinery and apparatus intended to form or forming part of the Works.
- 1.1.17 “Site” means the places provided by the Employer where the Works are to be executed, and any other places specified in the Contract as forming part of the Site.
- 1.1.18 “Variation” means a change which is instructed by the Engineer/Employer under Sub-Clause 10.1.
- 1.1.19 “Works” means any or all the works whether Supply, Installation, Construction etc. and design (if any) to be performed by the Contractor including temporary works and any variation thereof.
- 1.1.20 “Engineer” means the person notified by the Employer to act as Engineer for the purpose of the Contract and named as such in Contract Data.

1.2 Interpretation

Words importing persons or parties shall include firms and organizations. Words importing singular or one gender shall include plural or the other gender where the context requires.

1.3 Priority of Documents

The documents forming the Contract are to be taken as mutually explanatory of one another. If an ambiguity or discrepancy is found in the documents, the priority of the documents shall be in accordance with the order as listed in the Contract Data.

1.4 Law

The law of the Contract is the relevant Law of Islamic Republic of Pakistan.

1.5 **Communications**

All Communications related to the Contract shall be in English language.

1.6 **Statutory Obligations**

The Contractor shall comply with the Laws of Islamic Republic of Pakistan and shall give all notices and pay all fees and other charges in respect of the Works.

2. **THE EMPLOYER**

2.1 **Provision of Site**

The Employer shall provide the Site and right of access thereto at the times stated in the Contract Data.

2.2 **Permits etc.**

The Employer shall, if requested by the Contractor, assist him in applying for permits, licences or approvals which are required for the Works.

2.3 **Engineer's/Employer's Instructions**

The Contractor shall comply with all instructions given by the Employer or the Engineer, if notified by the Employer, in respect of the Works including the suspension of all or part of the Works.

2.4 **Approvals**

No approval or consent or absence of comment by the Engineer/Employer shall affect the Contractor's obligations.

3. **ENGINEER'S/EMPLOYER'S REPRESENTATIVES**

3.1 **Authorised Person**

The Employer shall appoint a duly authorized person to act for him and on his behalf for the purposes of this Contract. Such authorized person shall be duly identified in the Contract Data or otherwise notified in writing to the Contractor as soon as he is so appointed. In either case the Employer shall notify the Contractor, in writing, the precise scope of the authority of such authorized person at the time of his appointment.

3.2 **Engineer's/Employer's Representative**

The name and address of Engineer's/Employer's Representative is given in Contract Data. However, the Contractor shall be notified by the Engineer/Employer, the delegated duties and authority before the Commencement of Works.

4. THE CONTRACTOR

4.1 General Obligations

The Contractor shall carry out the Works properly and in accordance with the Contract. The Contractor shall provide all supervision, labour, Materials, Plant and Contractor's Equipment which may be required.

4.2 Contractor's Representative

The Contractor shall appoint a representative at site on full time basis to supervise the execution of work and to receive instructions on behalf of the Contractor but only after obtaining the consent of the Employer for such appointment which consent shall not be unreasonable withheld by the Employer. Such authorized representative may be substituted/replaced by the Contractor at any time during the Contract Period but only after obtaining the consent of the Employer as aforesaid.

4.3 Subcontracting

The Contractor shall not subcontract the whole of the Works. The Contractor shall not subcontract any part of the Works without the consent of the Employer.

4.4 Performance Security

The Contractor shall furnish to the Employer within fourteen (14) days after receipt of Letter of Acceptance a Performance Security @ 10% of the contract amount at the option of the bidder, in the form of Bank Draft or Bank Guarantee for the amount and validity specified in Contract Data.

5. DESIGN BY CONTRACTOR

5.1 Contractor's Design

The Contractor shall carry out design to the extent specified, as referred to in the Contract Data. The Contractor shall promptly submit to the Engineer/Employer all designs prepared by him. Within fourteen (14) days of receipt the Engineer/Employer shall notify any comments or, if the design submitted is not in accordance with the Contract, shall reject it stating the reasons. The Contractor shall not construct any element of the Works designed by him within fourteen (14) days after the design has been submitted to the Engineer/Employer or which has been rejected. Design that has been rejected shall be promptly amended and resubmitted. The Contractor shall resubmit all designs commented on taking these comments into account as necessary.

5.2 Responsibility for Design

The Contractor shall remain responsible for his bided design and the design under this Clause, both of which shall be fit for the intended purposes defined in the Contract and he shall also remain responsible for any infringement of any patent or copyright in respect of the same. The Engineer/Employer shall be responsible for the Specifications and Drawings.

6. EMPLOYER'S RISKS

6.1 The Employer's Risks

The Employer's Risks are:-

- a) war, hostilities (whether war be declared or not), invasion, act of foreign enemies, within the Country;
- b) rebellion, terrorism, revolution, insurrection, military or usurped power, or civil war, within the Country;
- c) riot, commotion or disorder by persons other than the Contractor's personnel and other employees including the personnel and employees of Sub-Contractors, affecting the Site and/or the Works;
- d) ionising radiations, or contamination by radio-activity from any nuclear fuel, or from any nuclear waste from the combustion of nuclear fuel, radio-active toxic explosive, or other hazardous properties of any explosive nuclear assembly or nuclear component of such an assembly, except to the extent to which the Contractor/Sub-Contractors may be responsible for the use of any radio-active material;
- e) Pressure waves caused by aircraft or other aerial devices travelling at sonic or supersonic speeds;
- f) use or occupation by the Employer of any part of the Works, except as may be specified in the Contract;
- g) late handing over of sites, anomalies in drawings, late delivery of designs and drawings of any part of the Works by the Employer's personnel or by others for whom the Employer is responsible;
- h) a suspension under Sub-Clause 2.3 unless it is attributable to the Contractor's failure; and
- i) physical obstructions or physical conditions other than climatic conditions, encountered on the Site during the performance of the Works, for which the Contractor immediately notified to the Employer and accepted by the Employer.

7. TIME FOR COMPLETION

7.1 Execution of the Works

The Contractor shall commence the Works on the Commencement Date and shall proceed expeditiously and without delay and shall complete the Works, subject to Sub-Clause 7.3 below, within the Time for Completion.

7.2 Programme

Within the time stated in the Contract Data, the Contractor shall submit to the Engineer/Employer a programmed for the Works in the form stated in the Contract Data.

7.3 **Extension of Time**

The Contractor shall, within such time as may be reasonable under the circumstances, notify the Employer/Engineer of any event(s) falling within the scope of Sub-Clause 6.1 or 10.3 of these Conditions of Contract and request the Employer/Engineer for a reasonable extension in the time for the completion of Works. Subject to the aforesaid, the Employer/Engineer shall determine such reasonable extension in the time for the completion of Works as may be justified in the light of the details/particulars supplied by the Contractor in connection with the such determination by the Employer/Engineer within such period as may be prescribed by the Employer/Engineer for the same; and

the Employer shall extend the Time for Completion as determined.

7.4 **Late Completion**

If the Contractor fails to complete the Works within the Time for Completion, the Contractor's only liability to the Employer for such failure shall be to pay the amount stated in the Contract Data for each day for which he fails to complete the Works.

8. **TAKING-OVER**

8.1 **Completion**

The Contractor may notify the Engineer/Employer when he considers that the Works are complete.

8.2 **Taking-Over Notice**

Within fourteen (14) days of the receipt of the said notice of completion from the Contractor the Employer/Engineer shall either takeover the completed Works and issue a Certificate of Completion to that effect or shall notify the Contractor his reasons for not taking-over the Works. While issuing the Certificate of Completion as aforesaid, the Employer/Engineer may identify any outstanding items of work which the Contractor shall undertake during the Maintenance Period.

9. **REMEDYING DEFECTS**

9.1 **Remedying Defects**

The Contractor shall for a period stated in the Contract Data from the date of issue of the Certificate of Completion carry out, at no cost to the Employer, repair and rectification work which is necessitated by the earlier execution of poor quality of work or use of below specifications material in the execution of Works and which is so identified by the Employer/Engineer in writing within the said period. Upon expiry of the said period, and subject to the Contractor's faithfully performing his aforesaid obligations, the Employer/Engineer shall issue a Maintenance Certificate whereupon all obligations of the Contractor under this Contract shall come to an end.

Failure to remedy any such defects or complete outstanding work within a reasonable time shall entitle the Employer to carry out all necessary works at the Contractor's cost. However, the cost of remedying defects not attributable to the Contractor shall be valued as a Variation.

9.2 **Uncovering and Testing**

The Engineer/Employer may give instruction as to the uncovering and/or testing of any work. Unless as a result of an uncovering and/or testing it is established that the Contractor's design, Materials, Plant or workmanship are not in accordance with the Contract, the Contractor shall be paid for such uncovering and/or testing as a Variation in accordance with Sub-Clause 10.2.

10. **VARIATIONS AND CLAIMS**

10.1 **Right to Vary**

The Employer/Engineer may issue Variation Order(s) in writing. Where for any reason it has not been possible for the Employer/Engineer to issue such Variations Order(s), the Contractor may confirm any verbal orders given by the Employer/Engineer in writing and if the same are not refuted/denied by the Employer/Engineer within seven (7) days of the receipt of such confirmation the same shall be deemed to be a Variation Orders for the purposes of this Sub- Clause.

10.2 **Valuation of Variations**

Variations shall be valued as follows:

- a) at a lump sum price agreed between the Parties, or
- b) where appropriate, at rates in the Contract, or
- c) in the absence of appropriate rates, the rates in the Contract shall be used as the basis for valuation, or failing which
- d) at appropriate new rates, as may be agreed or which the Engineer/Employer considers appropriate, or
- e) if the Engineer/Employer so instructs, at day work rates set out in the Contract Data for which the Contractor shall keep records of hours of labour and Contractor's Equipment, and of Materials, used, or
- f) Market Rate System (MRS) District Lahore issued by Govt. of the Punjab Finance Department.

10.3 **Early Warning**

The Contractor shall notify the Engineer/Employer in writing as soon as he is aware of any circumstance which may delay or disrupt the Works, or which may give rise to a claim for additional payment.

To the extent of the Contractor's failure to notify, which results to the Engineer/Employer being unable to keep all relevant records or not taking steps to minimise any delay, disruption, or Cost, or the value of any Variation, the Contractor's entitlement to extension of the Time for Completion or additional payment shall be reduced/rejected.

10.4. Valuation of Claims

If the Contractor incurs Cost as a result of any of the Employer's Risks, the Contractor shall be entitled to the amount of such Cost. If as a result of any Employer's Risk, it is necessary to change the Works, this shall be dealt with as a Variation subject to Contractor's notification for intention of claim to the Engineer/Employer within fourteen (14) days of the occurrence of cause.

10.5 Variation and Claim Procedure

The Contractor shall submit to the Engineer/Employer an itemized make-up of the value of variations and claims within twenty-eight (28) days of the instruction or of the event giving rise to the claim. The Engineer/Employer shall check and if possible, agree the value. In the absence of agreement, the Employer shall determine the value.

11. CONTRACT PRICE AND PAYMENT

11.1 (a) Terms of Payments

The amount due to the Contractor under any Interim Payment Certificate issued by the Engineer pursuant to this Clause, or to any other terms of the Contract, shall , subject to Clause 47, be paid by the Employer to the Contractor within 30 days after such Interim Payment Certificate has been jointly verified by Employer and Contractor, or, in the case of the Final Certificate referred to in Sub Clause 60.8, within 60 days after such Final Payment Certificate has been jointly verified by Employer and Contractor; Provided that the Interim Payment shall be caused in 42 days and Final Payment in 60 days in case of foreign funded project

(b) Valuation of the Works

The Works shall be valued as provided for in the Contract Data, subject to Clause 10.

11.2 Monthly Statements

The Contractor shall be entitled to be paid at monthly intervals:

- a) the value of the Works executed; and
- b) The percentage of the value of Materials and Plant reasonably delivered to the Site, as stated in the Contract Data, subject to any additions or deductions which may be due.

The Contractor shall submit each month to the Engineer/Employer a statement showing the amounts to which he considers himself entitled.

11.3 **Interim Payments**

Within a period not exceeding seven (7) days from the date of submission of a statement for interim payment by the Contractor, the Engineer shall verify the same and within a period not exceeding thirty (30) days from the said date of submission by the Contractor, the Employer shall pay to the Contractor the sum verified by the Engineer less retention money at the rate stated in the Contract Data.

11.4 **Retention**

Retention money shall be paid by the Employer to the Contractor within fourteen (14) days after either the expiry of the period stated in the Contract Data, or the remedying of notified defects, or the completion of outstanding work, all as referred to in Sub-Clause 9.1, which ever is the later.

11.5 **Final Payment**

Within twenty one (21) days from the date of issuance of the Maintenance Certificate the Contractor shall submit a final account to the Engineer to verify and the Engineer shall verify the same within fourteen (14) days from the date of submission and forward the same to the Employer together with any documentation reasonably required to enable the Employer to ascertain the final contract value.

Within sixty (60) days from the date of receipt of the verified final account from the Engineer, the Employer shall pay to the Contractor any amount due to the Contractor. While making such payment the Employer may, for reasons to be given to the Contractor in writing, withhold any part or parts of the verified amount.

11.6 **Currency**

Payment shall be in the currency stated in the Contract Data.

12. **DEFAULT**

12.1 **Default by Contractor**

If the Contractor abandons the Works, refuses or fails to comply with a valid instruction of the Engineer/Employer or fails to proceed expeditiously and without delay, or is, despite a written complaint, in breach of the Contract, the Employer may give notice referring to this Sub-Clause and stating the default.

If the Contractor has not taken all practicable steps to remedy the default within fourteen (14) days after receipt of the Employer's notice, the Employer may by a second notice given within a further twenty one (21) days, terminate the Contract. The Contractor shall then demobilise from the Site leaving behind any Contractor's Equipment which the Employer instructs, in the second notice, to be used for the completion of the Works at the risk and cost of the Contractor.

12.2 **Default by Employer**

If the Employer fails to pay in accordance with the Contract, or is, despite a written complaint, in breach of the Contract, the Contractor may give notice referring to this Sub-Clause and stating the default. If the default is not remedied within fourteen (14) days after the Employer's receipt of this notice, the Contractor may suspend the execution of all or parts of the Works.

If the default is not remedied within twenty eight (28) days after the Employer's receipt of the Contractor's notice, the Contractor may by a second notice given within a further twenty one (21) days, terminate the Contract. The Contractor shall then demobilise from the Site.

12.3 **Insolvency**

If a Party is declared insolvent under any applicable law, the other Party may by notice terminate the Contract immediately. The Contractor shall then demobilise from the Site leaving behind, in the case of the Contractor's insolvency, any Contractor's Equipment which the Employer instructs in the notice is to be used for the completion of the Works.

12.4 **Payment upon Termination**

After termination, the Contractor shall be entitled to payment of the unpaid balance of the value of the Works executed and of the Materials and Plant reasonably delivered to the Site, adjusted by the following:

- a) any sums to which the Contractor is entitled under Sub-Clause 10.4,
- b) any sums to which the Employer is entitled,
- c) if the Employer has terminated under Sub-Clause 12.1 or 12.3, the Employer shall be entitled to a sum equivalent to twenty percent (20%) of the value of parts of the Works not executed at the date of the termination, and
- d) if the Contractor has terminated under Sub-Clause 12.2 or 12.3, the Contractor shall be entitled to the cost of his demobilisation together with a sum equivalent to ten percent (10%) of the value of parts of the Works not executed at the date of termination.

The net balance due shall be paid or repaid within twenty-eight (28) days of the notice of termination.

13. **RISKS AND RESPONSIBILITIES**

13.1 **Contractor's Care of the Works**

Subject to Sub-Clause 9.1, the Contractor shall take full responsibility for the care of the Works from the Commencement Date until the date of the Employer's/Engineer's issuance of Certificate of Completion under Sub-Clause 8.2. Responsibility shall then pass to the Employer. If any loss or damage happens

to the Works during the above period, the Contractor shall rectify such loss or damage so that the Works conform with the Contract.

Unless the loss or damage happens as a result of any of the Employer's Risks, the Contractor shall indemnify the Employer, or his agents against all claims loss, damage and expense arising out of the Works.

13.2 **Force Majeure**

If Force Majeure occurs, the Contractor shall notify the Engineer/Employer immediately. If necessary, the Contractor may suspend the execution of the Works and, to the extent agreed with the Employer demobilise the Contractor's Equipment.

If the event continues for a period of eighty four (84) days, either Party may then give notice of termination which shall take effect twenty eight (28) days after the giving of the notice.

After termination, the Contractor shall be entitled to payment of the unpaid balance of the value of the Works executed and of the Materials and Plant reasonably delivered to the Site, adjusted by the following:

- a) any sums to which the Contractor is entitled under Sub-Clause 10.4,
- b) the cost of his demobilization, and
- c) less any sums to which the Employer is entitled.

The net balance due shall be paid or repaid within thirty five (35) days of the notice of termination.

14. **INSURANCE**

14.1 **Arrangements**

The Contractor shall, prior to commencing the Works, effect insurances of the types, in the amounts and naming as insured the persons stipulated in the Contract Data except for items (a) to (e) and (i) of the Employer's Risks under Sub-Clause 6.1. The policies shall be issued by insurers and in terms approved by the Employer. The Contractor shall provide the Engineer/Employer with evidence that any required policy is in force and that the premiums have been paid.

14.2 **Default**

If the Contractor fails to effect or keep in force any of the insurances referred to in the previous Sub-Clause, or fails to provide satisfactory evidence, policies or receipts, the Employer may, without prejudice to any other right or remedy, effect insurance for the cover relevant to such as a default and pay the premiums due and recover the same plus a sum in percentage given in Contractor Data from any other amounts due to the Contractor.

15. RESOLUTION OF DISPUTES

15.1 Engineer's Decision

If a dispute of any kind whatsoever arises between the Employer and the Contractor in connection with the Works, the matter in dispute shall, in the first place, be referred in writing to the Engineer, with a copy to the other party. Such reference shall state that it is made pursuant to this Clause. No later than the twenty-eight (28) days after the day on which he received such reference, the Engineer shall give notice of his decision to the Employer and the Contractor.

Unless the Contract has already been repudiated or terminated, the Contractor shall, in every case, continue to proceed with the Work with all due diligence, and the Contractor and the Employer shall give effect forthwith to every such decision of the Engineer unless and until the same shall be revised, as hereinafter provided in an arbitral award.

15.2 Notice of Dissatisfaction

If a Party is dissatisfied with the decision of the Engineer or if no decision is given within the time set out in Sub-Clause 15.1 hereabove, the Party may give notice of dissatisfaction referring to this Sub-Clause within fourteen (14) days of receipt of the decision or the expiry of the time for the decision. If no notice of dissatisfaction is given within the specified time, the decision shall be final and binding on the Parties. If notice of dissatisfaction is given within the specified time, the decision shall be binding on the Parties who shall give effect to it without delay unless and until the decision of the Engineer is revised by an arbitrator.

15.3 Arbitration

A dispute which has been the subject of a notice of dissatisfaction shall be finally settled as per provisions of Arbitration Act 1940 (Act No. X of 1940) and Rules made thereunder and any statutory modifications thereto. Any hearing shall be held at the place specified in the Contract Data and in the language referred to in Sub-Clause 1.5.

16 INTEGRITY PACT

16.1 If the Contractor, or any of his Sub-Contractors, agents or servants is found to have violated or involved in violation of the Integrity Pact signed by the Contractor as Schedule-F to his Bid, then the Employer shall be entitled to:

(a) recover from the Contractor an amount equivalent to ten times the sum of any commission, gratification, bribe, finder's fee or kickback given by the Contractor or any of his Sub-Contractors, agents or servants;

(b) terminate the Contract; and

(b) recover from the Contractor any loss or damage to the Employer as a result of such termination or of any other corrupt business practices of the Contractor or any of his Sub-Contractors, agents or servants.

On termination of the Contract under Sub-Para (b) of this Sub-Clause, the Contractor shall demobilize from the Site leaving behind Contractor's Equipment which the Employer instructs, in the termination notice, to be used for the completion of the Works at the risk and cost of the Contractor. Payment upon such termination shall be made under Sub-Clause 12.4, in accordance with Sub-Para (c) thereof, after having deducted the amounts due to the Employer under Sub-Para (a) and (c) of this Sub- Clause.

17. Liquidated Damages for Delay

If the Contractor fails to comply with the Time for Completion in accordance with Clause 48, for the whole of the Works or, if applicable, any Section within the relevant time prescribed in the Contract, then the Contractor shall pay to the Employer the relevant sum stated in the C o n t r a c t D a t a as liquidated damages for such default and not as a penalty (which sum shall be the only monies due from the Contractor for such default) for every day or part of a day which shall elapse between the relevant Time for Completion and the date stated in a Taking-Over Certificate of the whole of the Works or the relevant Section, subject to the applicable limit stated in the Appendix to Tender. The Employer may, without prejudice to any other method of recovery, deduct the amount of such damages from any monies due or to become due to the Contractor. The payment or deduction of such damages shall not relieve the Contractor from his obligation to complete the Works, or from any other of his obligations and liabilities under the Contract.

CONTRACT DATA

Conditions of Contract

1.1.4 **The Employer** means;
General Manager Estate (GM-E), Gate no 02 Board of Management, Sundar Industrial Estates, Sundar-Raiwind Road, Lahore.

1.1.5 **The Contractor** means;

“CONSTRUCTION OF STORE BACK SIDE OF RESCUE BUILDING AT SIE”.

1.1.7 **Commencement Date** means;
The date of issuance of Engineer’s Notice to Commence which shall be issued within fourteen (14) days of the signing of the Contract Agreement.

1.1.9 **Time for Completion:** 150 Days.

1.1.20 **The Engineer:**

Snr. Estate Engineer / HOD BCD

1.3 **Documents forming the Contract listed in the order of priority:**

- (a) The Contract Agreement
- (b) Letter of Acceptance
- (c) The completed Form of Bid
- (d) Contract Data
- (e) Conditions of Contract
- (f) The completed Schedules to Bid including Schedule of Prices
- (g) The Drawings, if any
- (h) The Specifications
- (i) _____
- (j) _____

(The Employer may add, in order of priority, such other documents as form part of the Contract. Delete the document, if not applicable)

2.1 **Provision of Site:**

Commencement will be The Date for provision of Site.

3.1 **Authorized person:**

As nominated by Estate Engineer / HOD BCD

3.2 **Name and address of Engineer’s/Employer’s representative**

As nominated by The Employer

4.4 **Performance Security:**

10% of the Contract Amount in shape of Bank Guarantee from a Scheduled Bank in Pakistan Validity: Performance Security will remain valid till successful completion of DLP period i.e 12-months

5.1 **Requirements for Contractor's design (if any):**

Not Applicable

7.2 **Programme:**

Time for submission:

Within Ten (10) days of the receipt of Acceptance Letter.

9.1 **Period for remedying defects**

Minimum 12-months effective from issuance of Taking Over Certificate.

11.1 **Terms of Payments**

Add following at the end of paragraph 11.1 (a)

“The quantities given in the BOQ are merely an estimation. Payment shall be made as per actual work done dully verified by the The Engineer-BOM-SIE and certified by the “The Engineer” of the Project.”

11.3 **Percentage of retention:**

Retention money equal to Five (05%) of the Work done will be deducted from each payment and will be released after successful completion of Defect Liability period (DLP).

11.6 **Currency of payment:**

Pak. Rupees

14.1 **Insurances:
(Not Applicable)**

**Type of cover
(Not Applicable)**

**Amount of cover
(Not Applicable)**

**Type of cover
(Not Applicable):**

**Amount of cover
(Not Applicabl**

Type of cover
(Not Applicable)

Amount of cover
(Not Applicable)

15.3 **Arbitration**

Place of Arbitration: Lahore.

17. Liquidated Damages for Delay

In the fifth line of Sub-clause deletes the words “and not as penalty”

Add the following paragraph at the end of Sub-Clause

The rate of liquidated damages shall be at the rate of 0.1 Percent per day up to maximum of Ten (10) Percent of Contract Price).

STANDARD FORMS

FORM OF BID SECURITY
(Bank Guarantee)

Guarantee No. _____
Executed on _____

(Letter by the Guarantor to the Employer)

Name of Guarantor (Scheduled Bank in Pakistan)
with address: _____

Name of Principal (Bidder)
with address: _____

Penal Sum of Security (express in words
and figures): _____

Bid Reference No. _____ Date of Bid _____

KNOW ALL MEN BY THESE PRESENTS, that in pursuance of the terms of the Bid and at the request of the said Principal, we the Guarantor above-named are held and firmly bound

unto _____, (hereinafter called The "Employer")
the _____ in

the sum stated above, for the payment of which sum well and truly to be made, we bind ourselves, our heirs, executors, administrators and successors, jointly and severally, firmly by these presents.

THE CONDITION OF THIS OBLIGATION IS SUCH, that whereas the Principal has submitted the accompanying Bid numbered _____ and dated as above for _____ (Particulars of Bid) to the said Employer;
and

WHEREAS, the Employer has required as a condition for considering the said Bid that the Principal furnishes a Bid Security in the above said sum to the Employer, conditioned as under:

- (1) that the Bid Security shall remain valid for a period of twenty eight (28) days beyond the period of validity of the bid;
- (2) that in the event of;
 - (a) the Principal withdraws his Bid during the period of validity of Bid, or
 - (b) the Principal does not accept the correction of his Bid Price, pursuant to Sub- Clause 16.4 (b) of Instructions to Bidders, or
 - (c) failure of the successful bidder to
 - (i) furnish the required Performance Security, in accordance with Sub- Clause IB-21.1 of Instructions to Bidders, or

(ii) sign the proposed Contract Agreement, in accordance with Sub- Clauses IB-20.2 & 20.3 of Instructions to Bidders,

the entire sum be paid immediately to the said Employer for delayed completion and not as penalty for the successful bidder's failure to perform.

NOW THEREFORE, if the successful bidder shall, within the period specified therefore, on the prescribed form presented to him for signature enter into a formal Contract Agreement with the said Employer in accordance with his Bid as accepted and furnish within fourteen (14) days of receipt of Letter of Acceptance, a Performance Security with good and sufficient surety , as may be required, upon the form prescribed by the said Employer for the faithful performance and proper fulfilment of the said Contract or in the event of non-withdrawal of the said Bid within the time specified then this obligation shall be void and of no effect, but otherwise to remain in full force and effect.

PROVIDED THAT the Guarantor shall forthwith pay to the Employer the said sum stated above upon first written demand of the Employer without cavil or argument and without requiring the Employer to prove or to show grounds or reasons for such demand, notice of which shall be sent by the Employer by registered post duly addressed to the Guarantor at its address given above.

PROVIDED ALSO THAT the Employer shall be the sole and final judge for deciding whether the Principal has duly performed his obligations to sign the Contract Agreement and to furnish the requisite Performance Security within the time stated above, or has defaulted in fulfilling said requirements and the Guarantor shall pay without objection the sum stated above upon first written demand from the Employer forthwith and without any reference to the Principal or any other person.

IN WITNESS WHEREOF, the above bounded Guarantor has executed the instrument under its seal on the date indicated above, the name and seal of the Guarantor being hereto affixed and these presents duly signed by its undersigned representative pursuant to authority of its governing body.

Guarantor (Bank)

Witness: _____

1. Signature _____

1. _____

2. Name _____

Corporate Secretary (Seal)

3. Title _____

2. _____

(Name, Title & Address)

Corporate Guarantor (Seal)

**FORM OF PERFORMANCE SECURITY (Bank
Guarantee)**

Guarantee No. _____
Executed on _____

(Letter by the Guarantor to the
Employer)

Name of Guarantor (Scheduled Bank in Pakistan)

with address: _____

Name of Principal (Contractor)

with address: _____

Penal Sum of Security (express in words and
figures) _____

Letter of Acceptance _____ Dated _____
No.

KNOW ALL MEN BY THESE PRESENTS, that in pursuance of the terms of the Bidding Documents and above said Letter of Acceptance (hereinafter called the Documents) and at the request of the said Principal we, the Guarantor above named, are held and firmly bound unto the (hereinafter called the Employer) in the penal sum of the amount stated above, for the payment of which sum well and truly to be made to the said Employer, we bind ourselves, our heirs, executors, administrators and successors, jointly and severally, firmly by these presents.

THE CONDITION OF THIS OBLIGATION IS SUCH, that whereas the Principal has accepted the Employer's above said Letter of Acceptance for _____ (Name of Contract) _____ for the

_____ (Name of
Project).

NOW THEREFORE, if the Principal (Contractor) shall well and truly perform and fulfill all the undertakings, covenants, terms and conditions of the said Documents during the original terms of the said Documents and any extensions thereof that may be granted by the Employer, with or without notice to the Guarantor, which notice is, hereby, waived and shall also well and truly perform and fulfill all the undertakings, covenants terms and conditions of the Contract and of any and all modifications of the said Documents that may hereafter be made, notice of which modifications to the Guarantor being hereby waived, then, this obligation to be void; otherwise to remain in full force and virtue till all requirements of Clause 9, Remedying Defects, of Conditions of Contract are fulfilled.

Our total liability under this Guarantee is limited to the sum stated above and it is a condition of any liability attaching to us under this Guarantee that the claim for payment in writing shall be received by us within the validity period of this Guarantee, failing which we shall be discharged of our liability, if any, under this Guarantee.

We, _____ (the Guarantor), waiving all objections and defences under the Contract, do hereby irrevocably and independently guarantee to pay to the Employer without delay upon the Employer's first written demand without cavil or arguments and without requiring the Employer to prove or to show grounds or reasons for such demand any sum or sums up to the amount stated above, against the Employer's written declaration that the Principal has refused or failed to perform the obligations under the Contract, for which payment will be effected by the Guarantor to Employer's designated Bank & Account Number.

PROVIDED ALSO THAT the Employer shall be the sole and final judge for deciding whether the Principal (Contractor) has duly performed his obligations under the Contract or has defaulted in fulfilling said obligations and the Guarantor shall pay without objection any sum or sums up to the amount stated above upon first written demand from the Employer forthwith and without any reference to the Principal or any other person.

IN WITNESS WHEREOF, the above bounded Guarantor has executed this Instrument under its seal on the date indicated above, the name and corporate seal of the Guarantor being hereto affixed and these presents duly signed by its undersigned representative, pursuant to authority of its governing body.

	_____ Guarantor (Bank)
Witness:	
1. _____	1. Signature _____
_____	2. Name _____
Corporate Secretary	3. Title _____
(Seal)	
2. _____	
_____	_____
(Name, Title & Address)	Corporate Guarantor (Seal)

FORM OF CONTRACT AGREEMENT

THIS CONTRACT AGREEMENT (hereinafter called the “Agreement”) made on the ____ day of _____ 200 ____ between _____ (hereinafter called the “Employer”) of the one part and _____ (hereinafter called the “Contractor”) of the other part.

WHEREAS the Employer is desirous that certain Works, viz should be executed by the Contractor and has accepted a Bid by the Contractor for the execution and completion of such Works and the remedying of any defects therein.

NOW this Agreement witnesseth as follows:

1. In this Agreement words and expressions shall have the same meanings as are respectively assigned to them in the Conditions of Contract hereinafter referred to.
2. The following documents after incorporating addenda, if any except those parts relating to Instructions to Bidders, shall be deemed to form and be read and construed as part of this Agreement, viz:
 - (a) The Letter of Acceptance;
 - (b) The completed Form of Bid alongwith Schedules to Bid;
 - (c) Conditions of Contract & Contract Data;
 - (d) The priced Schedule of Prices;
 - (e) The Specifications;
 - and
 - (f) The Drawings
3. In consideration of the payments to be made by the Employer to the Contractor as hereinafter mentioned, the Contractor hereby covenants with the Employer to execute and complete the Works and remedy defects therein in conformity and in all respects within the provisions of the Contract.
4. The Employer hereby covenants to pay the Contractor, in consideration of the execution and completion of the Works as per provisions of the Contract, the Contract Price or such other sum as may become payable under the provisions of the Contract at the times and in the manner prescribed by the Contract.

IN WITNESS WHEREOF the parties hereto have caused this Contract Agreement to be executed on the day, month and year first before written in accordance with their respective laws.

Signature of the Contactor
Employer _____

(Seal)

Signature of the

(Seal)

Signed, Sealed and Delivered in the presence of:

Witness:

(Name, Title and Address)

Witness:

(Name, Title and Address)

FORM OF BANK GUARANTEE FOR ADVANCE PAYMENT

Guarantee No. _____

Executed on _____

(Letter by the Guarantor to the Employer)

WHEREAS the _____ (hereinafter called the Employer) has entered into a Contract for _____

_____ (Particulars of Contract),
with _____

_____ (hereinafter called the Contractor).

AND WHEREAS the Employer has agreed to advance to the Contractor, at the Contractor's

request, an amount of Rs. _____ Rupees _____)

which amount shall be advanced to the Contractor as per provisions of the Contract.

AND WHEREAS the Employer has asked the Contractor to furnish Guarantee to secure the advance payment for the performance of his obligations under the said Contract.

AND WHEREAS _____ (Scheduled Bank) (hereinafter called the Guarantor) at the request of the Contractor and in consideration of the Employer agreeing to make the above advance to the Contractor, has agreed to furnish the said Guarantee.

NOW THEREFORE the Guarantor hereby guarantees that the Contractor shall use the advance for the purpose of above mentioned Contract and if he fails, and commits default in fulfillment of any of his obligations for which the advance payment is made, the Guarantor shall be liable to the Employer for payment not exceeding the aforementioned amount.

Notice in writing of any default, of which the Employer shall be the sole and final judge, as aforesaid, on the part of the Contractor, shall be given by the Employer to the Guarantor, and on such first written demand payment shall be made by the Guarantor of all sums then due under this Guarantee without any reference to the Contractor and without any objection.

This Guarantee shall come into force as soon as the advance payment has been credited to the account of the Contractor.

This Guarantee shall expire not later than _____

by which date we must have received any claims by registered letter, telegram, telex or telefax.

It is understood that you will return this Guarantee to us on expiry or after settlement of the total amount to be claimed hereunder.

	_____ Guarantor (Scheduled Bank)
Witness:	
1. _____	1. Signature _____
_____	2. Name _____
Corporate Secretary (Seal)	3. Title _____
2. _____	
_____	_____
(Name, Title & Address)	Corporate Guarantor (Seal)

TECHNICAL SPECIFICATIONS

**(Technical specification of MRS, issued by
Finance
Department Govt. of Punjab will be
used)**

RCC DRAIN MESH
AT SDS

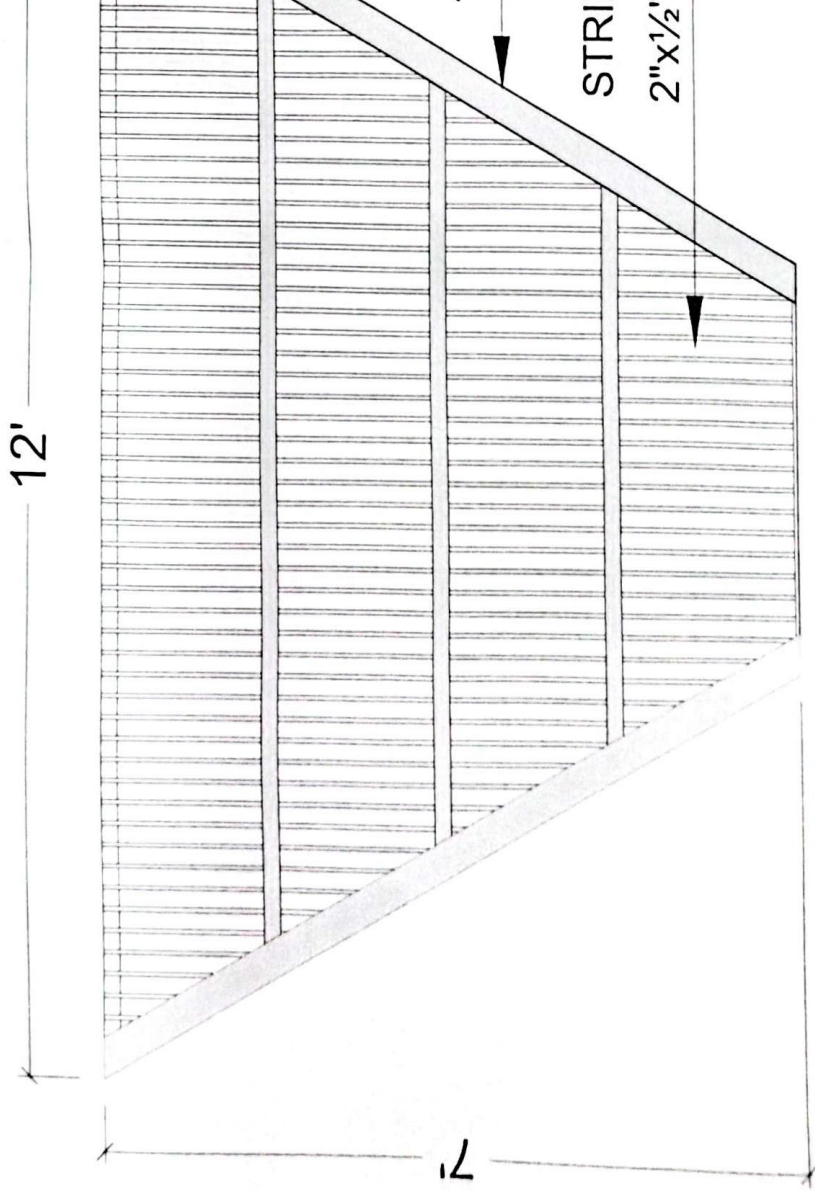

ELEVATION

PLOT 710

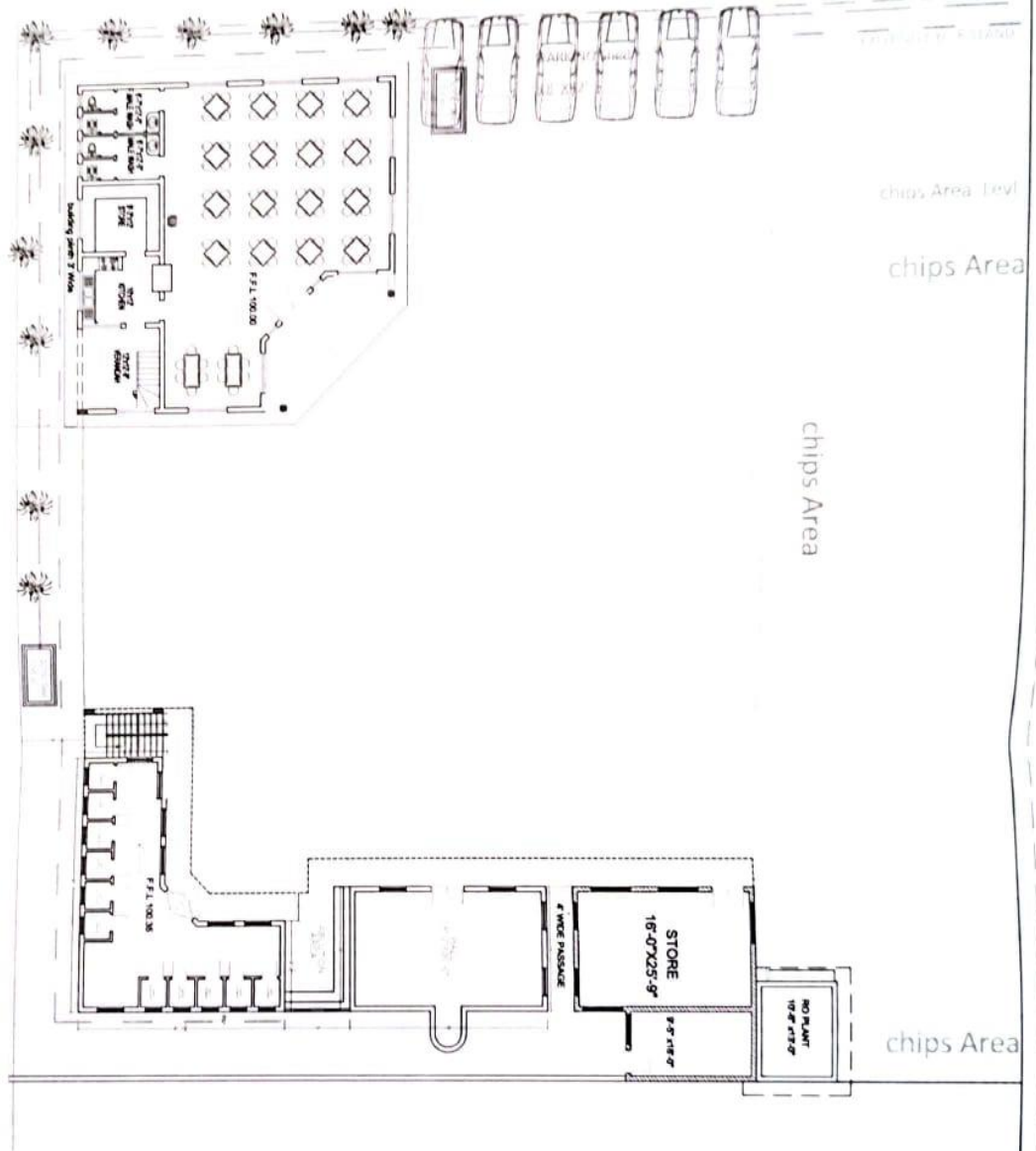

GROUND FLOOR WORKING PLAN

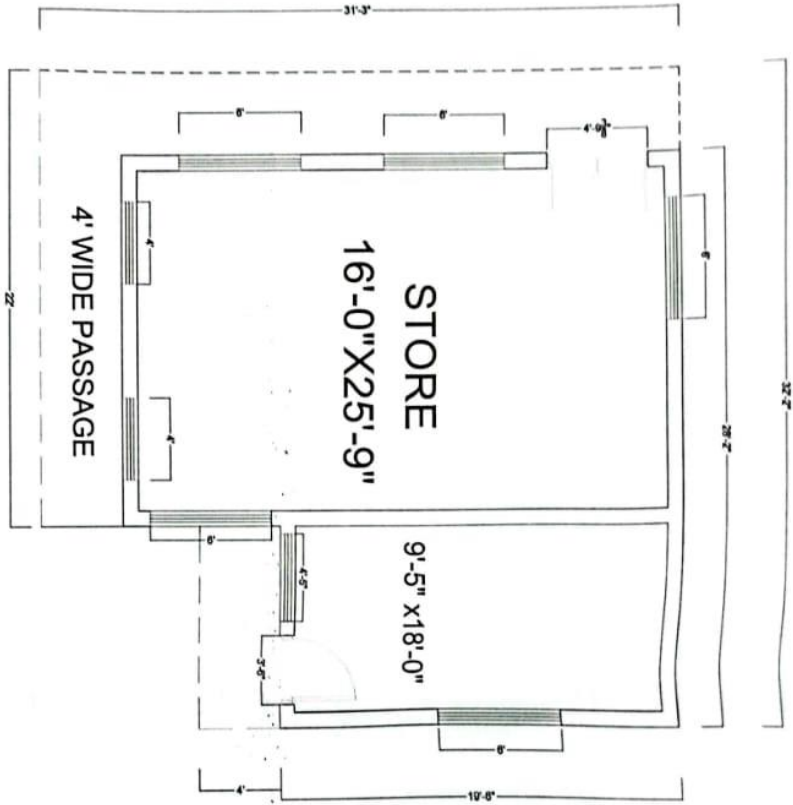

1ST FLOOR WORKING PLAN

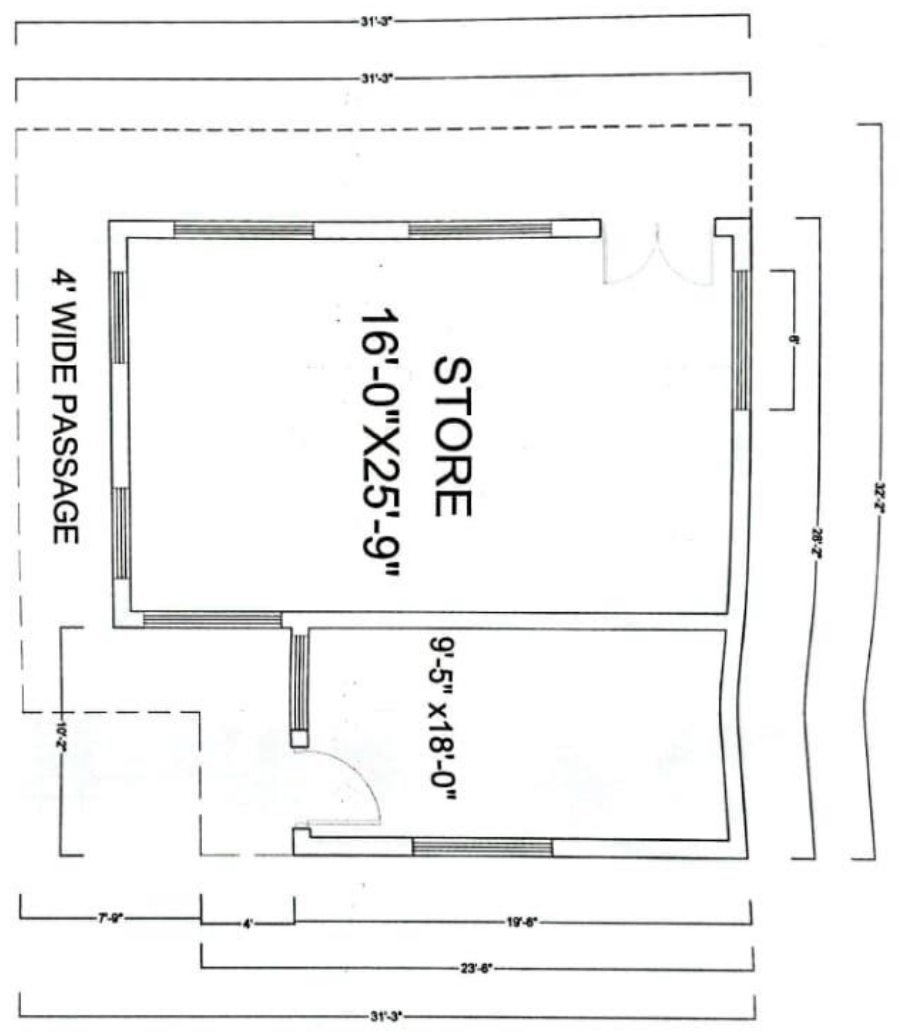

SECTION AT, A-A

1:12TH TERRAZZO DOOR
1:12TH TERRAZZO DOOR
2:12TH TERRAZZO DOOR
CONCRETE SLAB

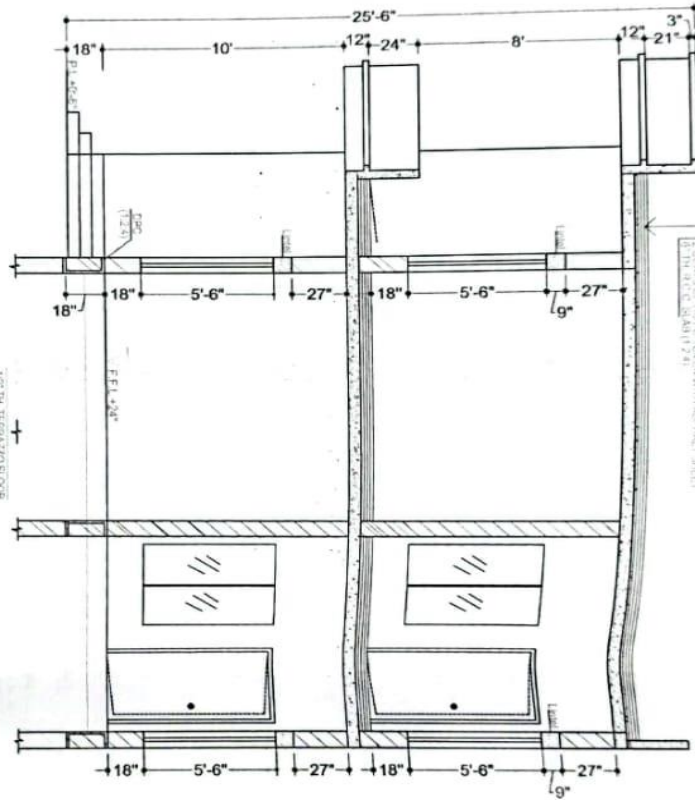

Excavation Lay Out Plan

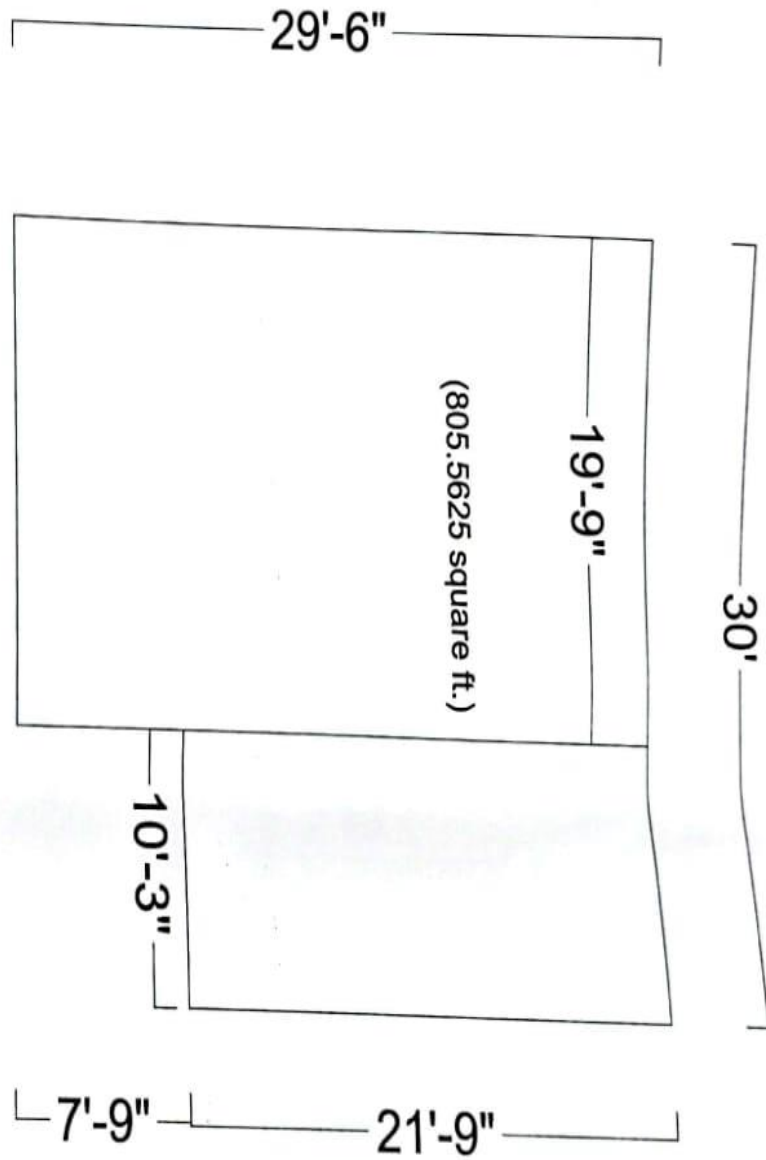

Foundation Lay Out Plan

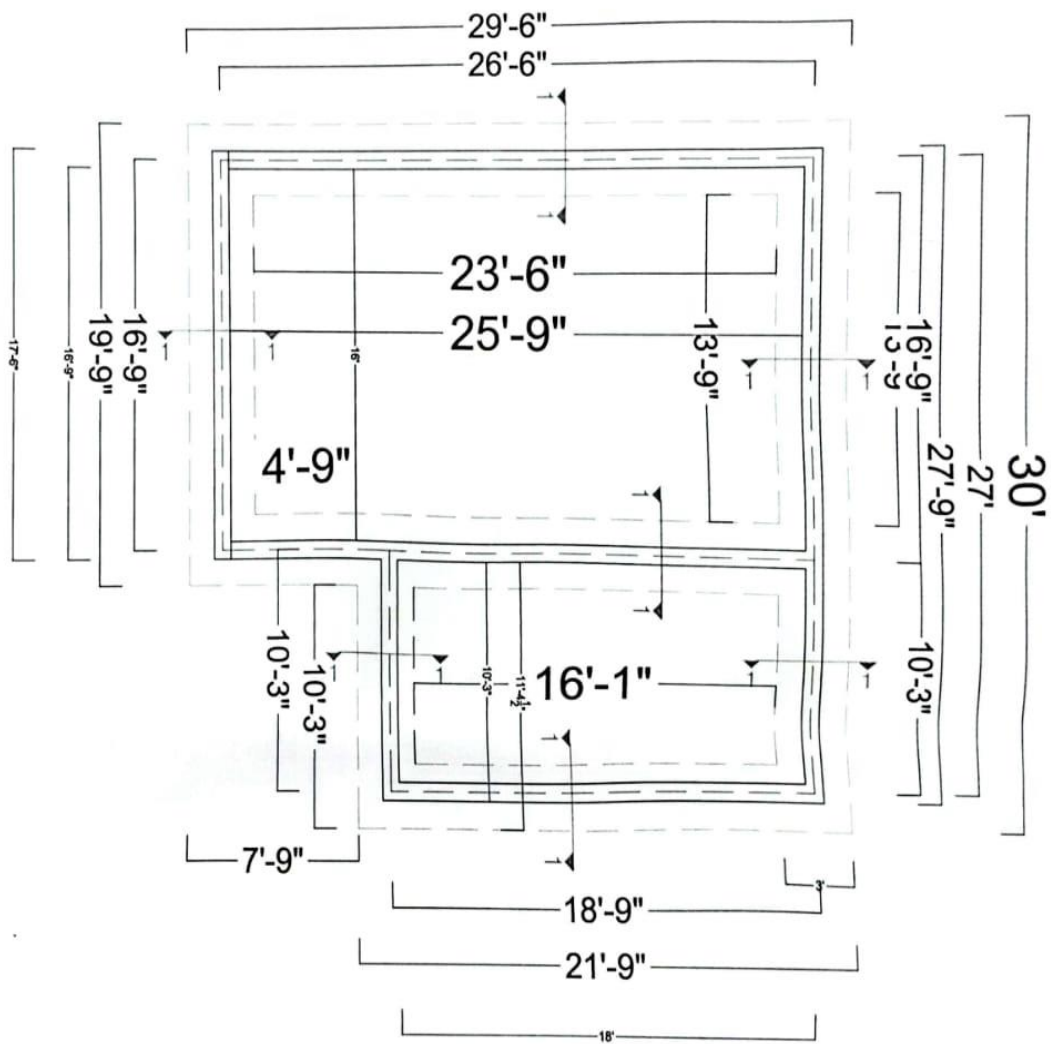

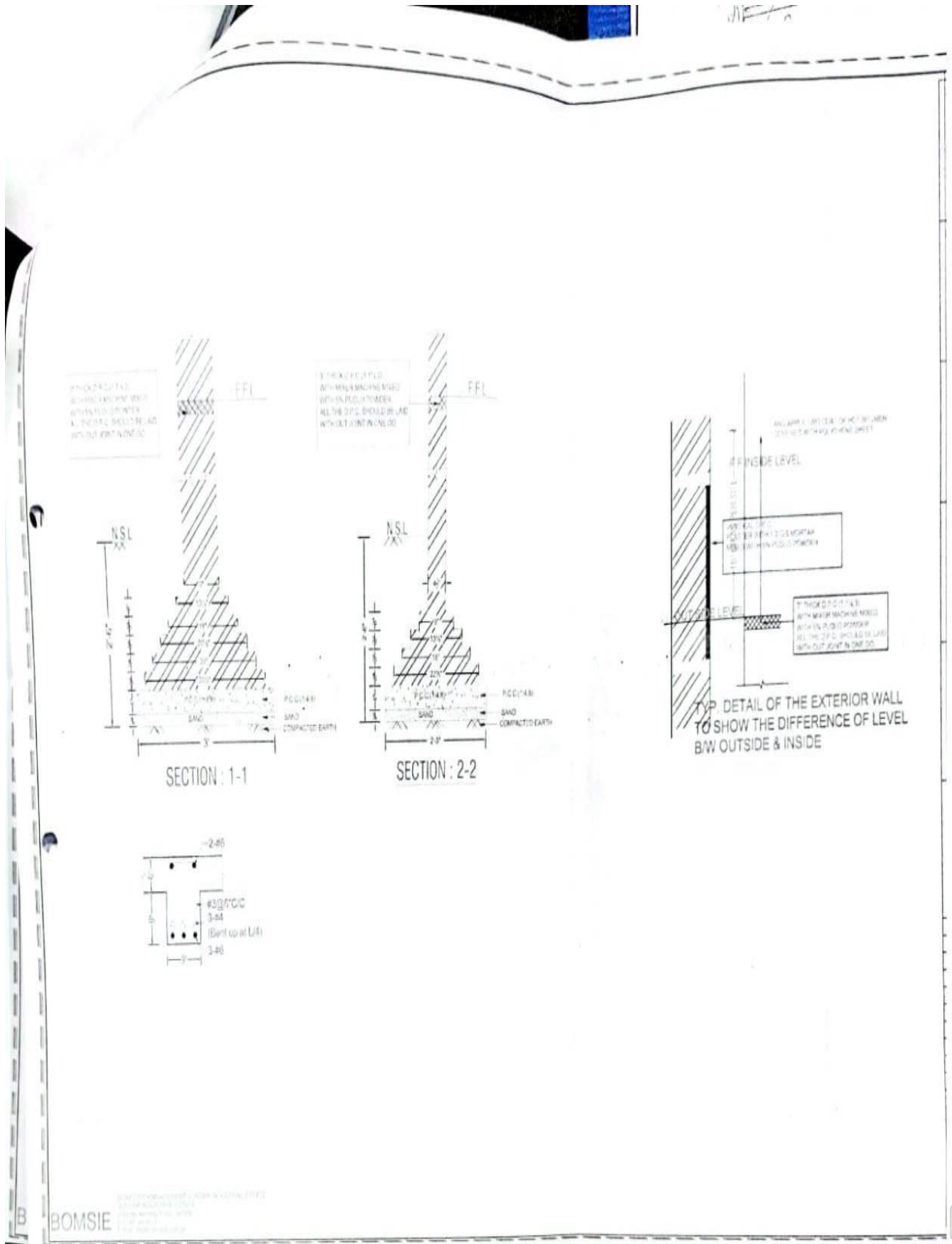

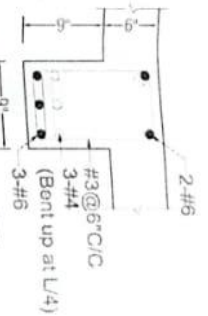
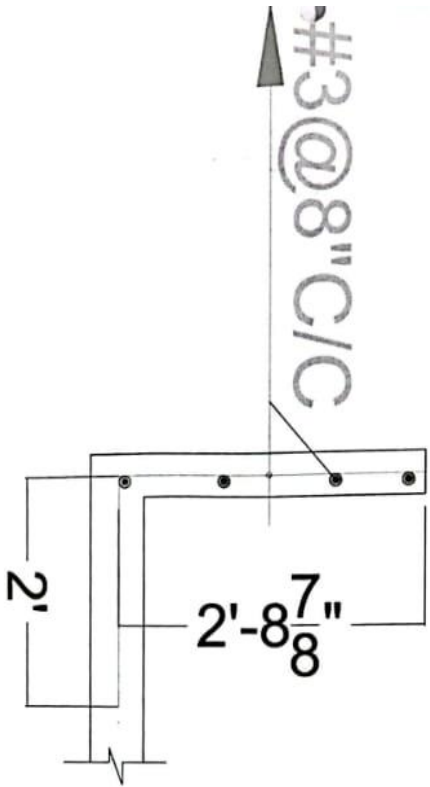

PARAPET WALL REINFORCEMENT

Typ. Sec. Of Beam-B1

